



■ Made
■ in
■ Germany



Fräswerkzeuge für die moderne 5-Achs-Bearbeitung
End Mills for the Advanced 5-Axis Operation



Kreissegment-Fräser
Circle Segment End Mills

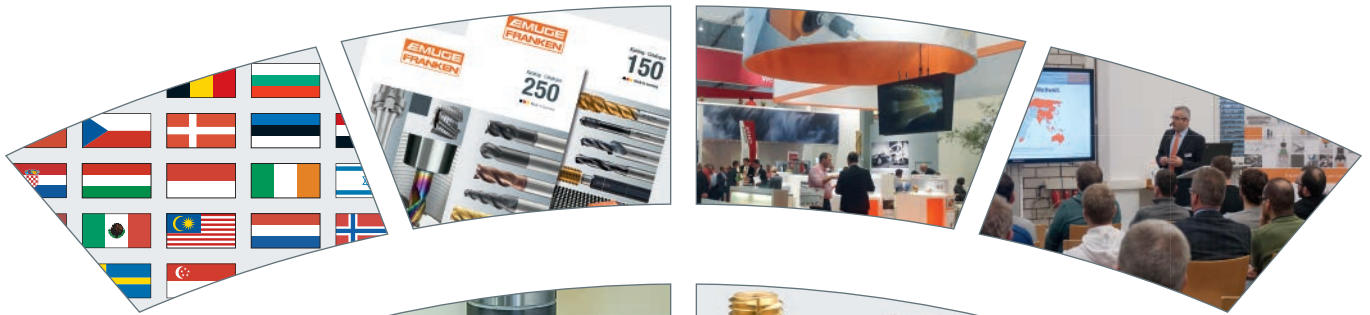

Mit den Kreissegment-Fräsern wurde eine Werkzeugfamilie geschaffen, welche einen höheren Bahnabstand bei der Schrupp-, Vorschlicht- und Schlichtbearbeitung erlaubt. Diese Werkzeuge kommen vorwiegend im Formenbau sowie bei der Herstellung von Reifenformen, Turbinenschaufeln, Impellerblättern oder Blisks zum Einsatz.

Die technische Besonderheit dieser Fräser liegt bei den großen Radien im schneidenden Bereich der jeweiligen Ausführung, welche ganz neue Möglichkeiten in der Zerspanung bieten. Der große Radius simuliert einen Kugelfräser mit einem Schneidendurchmesser von 12 bis 3000 mm, auf Anfrage sogar größer.

Eine wichtige Rolle spielt hierbei das CAM-System, welches die Geometrie der Kreissegment-Fräser unterstützen und verrechnen muss. Somit können Bearbeitungszeiten drastisch reduziert und im Gegenzug die Oberflächenqualität der Bauteile erhöht werden.

Vier verschiedene Formen von Kreissegment-Fräsern stehen zur Verfügung:

- Tonnenform
- Tropfenform
- Kegelform
- Linsenform

The circle segment end mills constitute a new tool class which enable machining with a larger tool path distance during roughing, pre-finishing and finishing operations. These tools are primarily used in mould-making as well as in the production of tyre moulds, turbine blades, impeller blades or blisks.

The technical specialty of these end mills are the large radii in the cutting area of the respective tool which offer entirely new possibilities in machining. The large radius simulates a ball-nose end mill with a cutting diameter of 12 to 3000 mm and even larger on request.

The CAM system which has to support and compute the geometry of the circle segment end mill, plays an important role here. As a consequence, machining times can be reduced significantly and at the same time the surface quality of the components is increased.

There are four different types of circle segment end mills available:

- Barrel form
- Oval form
- Taper form
- Lens form

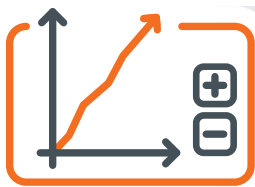

Wirtschaftlichkeitsberechnung für Kreissegment-Fräser

Economical calculation for circle segment end mills

www.frankenexpert.com



Vergleichsbeispiel: Kugelfräser – Kreissegment-Fräser mit Tropfenform – VR
Comparison example: Ball nose end mill – Circle segment end mill with oval form – VR

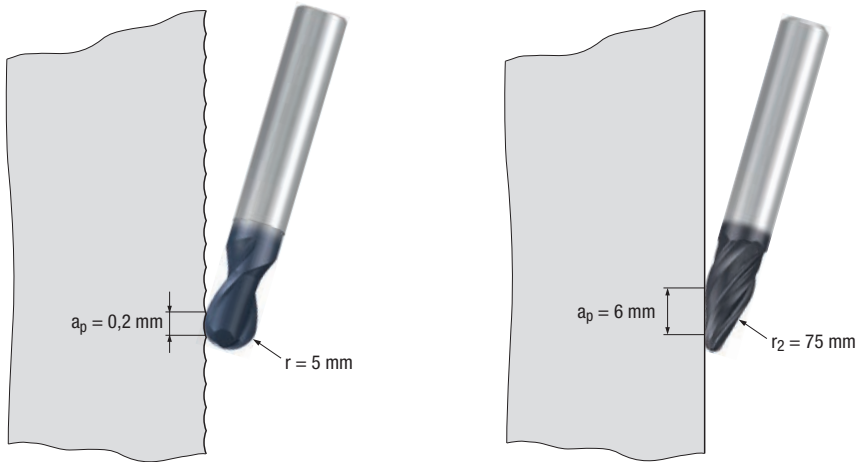

Ergebnis:
Kreissegment-Fräser ermöglichen eine höhere axiale Zustellung (a_p) bei wesentlich besseren Oberflächengüten.

Result:
Circle segment end mills enable a larger axial depth of cut (a_p) and a considerably better surface finish.

Übersicht der Kreissegment-Fräserformen
Overview of types of circle segment end mills

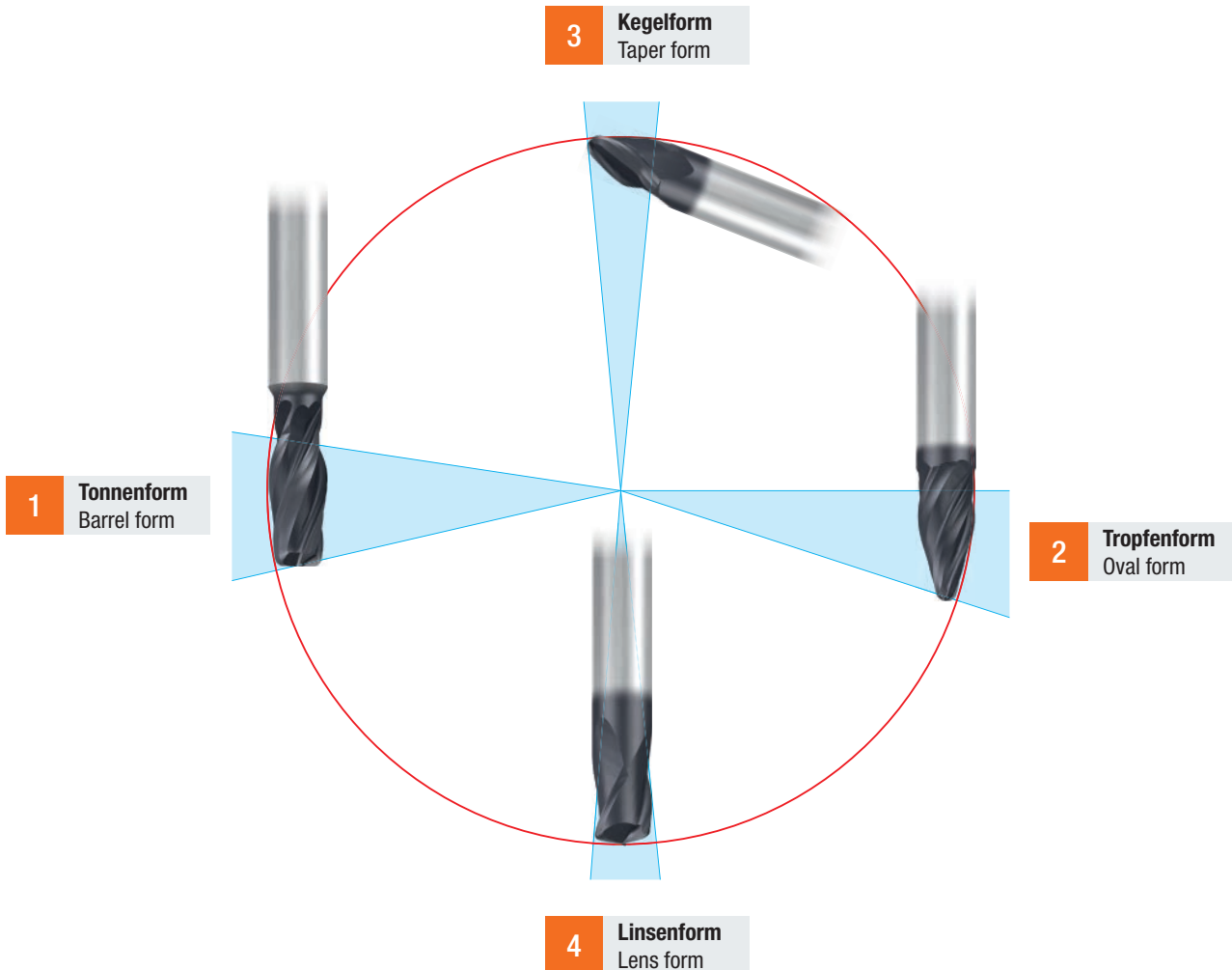

1 Tonnenform – ER
Barrel form – ER



Art.-Nr.	3542L.10050A
Dimension	∅ 10 mm, r ₁ = 2 mm, r ₂ = 50 mm
Z (Flutes)	4
v _c	225 m/min
n	7 150 min ⁻¹
f _z	0,06 mm
v _f max.	1 700 mm/min
a _p	2,0 mm
a _e	0,3 mm

2 Tropfenform – VR
Oval form – VR



Art.-Nr.	3538L.06095A
Dimension	∅ 6 mm, r ₁ = 1 mm, r ₂ = 95 mm
Z (Flutes)	3
v _c	300 m/min
n	16 000 min ⁻¹
f _z	0,05 mm
v _f max.	2 400 mm/min
a _p	1,5 mm
a _e	0,2 mm

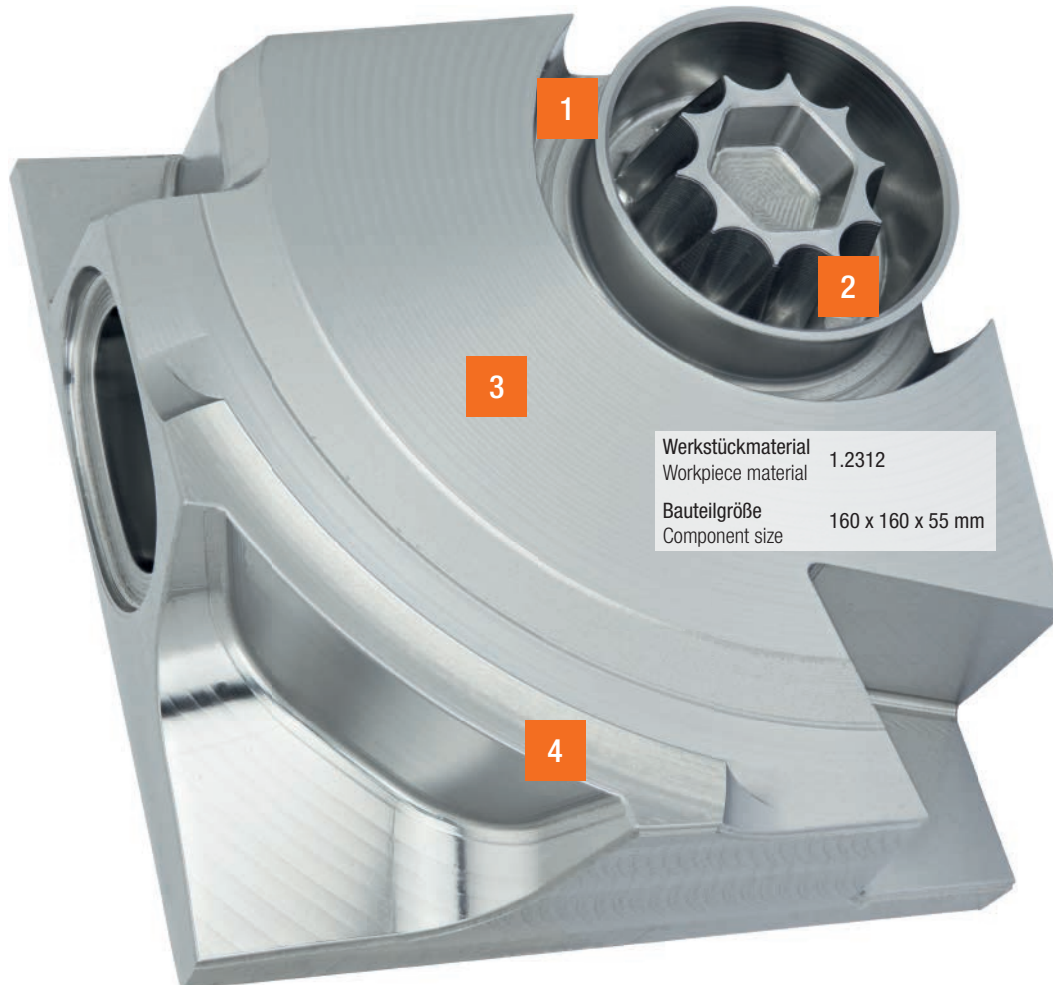

Werkstückmaterial 1.2312
Workpiece material
Bauteilgröße 160 x 160 x 55 mm
Component size



3 Kegelform – VR
Taper form – VR



Art.-Nr.	3540L.16500A
Dimension	∅ 16 mm, r ₁ = 4 mm, r ₂ = 500 mm
Z (Flutes)	3
v _c	400 m/min
n	8 000 min ⁻¹
f _z	0,06 mm
v _f max.	1 450 mm/min
a _p	0,3 mm
a _e	3,5 mm

4 Linsenform – ER
Lens form – ER



Art.-Nr.	3544L.10020A
Dimension	∅ 10 mm, r ₁ = 1 mm, r ₂ = 20 mm
Z (Flutes)	3
v _c	200 m/min
n	6 350 min ⁻¹
f _z	0,08 mm
v _f max.	1 500 mm/min
a _p	0,3 mm
a _e	1,2 mm

Wegweiser

Bitte beachten:

Die Eignung der Kreissegment-Fräser ist folgendermaßen gekennzeichnet:

- = sehr gut geeignet
- = gut geeignet

Die zugehörigen Schnittwerte sind auf den Seiten 9 - 26 zu finden.

Product finder

Please note:

The suitability of the circle segment end mills is indicated as follows:

- = very suitable
- = suitable

Please find the cutting conditions on pages 9 - 26.

Einsatzgebiete – Material Applications – material		Material-Beispiele Material examples	Material-Nummern Material numbers	
P	Stahlwerkstoffe Steel materials			
	1.1 Kaltfließpressstähle, Baustähle, Automatenstähle, u.a.	Cold-extrusion steels, Construction steels, Free-cutting steels, etc.	≤ 600 N/mm ²	Cq15 1.1132 S235JR (St37-2) 1.0037 10SPb20 1.0722
	2.1 Baustähle, Einsatzstähle, Stahlguss, u.a.	Construction steels, Case-hardened steels, Steel castings, etc.	≤ 800 N/mm ²	E360 (St70-2) 1.0070 16MnCr5 1.7131 GS-25CrMo4 1.7218
	3.1 Einsatzstähle, Vergütungsstähle, Kaltarbeitsstähle, u.a.	Case-hardened steels, Heat-treatable steels, Cold work steels, etc.	≤ 1000 N/mm ²	20MoCr3 1.7320 42CrMo4 1.7225 102Cr6 1.2067 50CrMo4 1.7228
	4.1 Vergütungsstähle, Kaltarbeitsstähle, Nitrierstähle, u.a.	Heat-treatable steels, Cold work steels, Nitriding steels, etc.	≤ 1200 N/mm ²	X45NiCrMo4 1.2767 31CrMo12 1.8515
5.1 Hochlegierte Stähle, Kaltarbeitsstähle, Warmarbeitsstähle, u.a.	High-alloyed steels, Cold work steels, Hot work steels, etc.	≤ 1400 N/mm ²	X38CrMoV5-3 1.2367 X100CrMoV8-1-1 1.2990 X40CrMoV5-1 1.2344	
M	Nichtrostende Stahlwerkstoffe Stainless steel materials			
	1.1 Ferritisch, martensitisch	Ferritic, martensitic	≤ 950 N/mm ²	X2CrTi12 1.4512
	2.1 Austenitisch	Austenitic	≤ 950 N/mm ²	X6CrNiMoTi17-12-2 1.4571
	3.1 Austenitisch-ferritisch (Duplex)	Austenitic-ferritic (Duplex)	≤ 1100 N/mm ²	X2CrNiMoN22-5-3 1.4462
4.1 Austenitisch-ferritisch hitzebeständig (Super Duplex)	Austenitic-ferritic heat-resistant (Super Duplex)	≤ 1250 N/mm ²	X2CrNiMoN25-7-4 1.4410	
K	Gusswerkstoffe Cast materials			
	1.1 Gusseisen mit Lamellengrafit (GJL)	Cast iron with lamellar graphite (GJL)	100-250 N/mm ²	EN-GJL-200 (GG20) EN-JL-1030
	2.1 Gusseisen mit Kugelgrafit (GJS)	Cast iron with nodular graphite (GJS)	250-450 N/mm ²	EN-GJL-300 (GG30) EN-JL-1050
	2.2 Gusseisen mit Kugelgrafit (GJS)	Cast iron with nodular graphite (GJS)	350-500 N/mm ²	EN-GJS-400-15 (GGG40) EN-JS-1030
	3.1 Gusseisen mit Vermiculargrafit (GJV)	Cast iron with vermicular graphite (GJV)	500-900 N/mm ²	EN-GJS-700-2 (GGG70) EN-JS-1070
	3.2 Gusseisen mit Vermiculargrafit (GJV)	Cast iron with vermicular graphite (GJV)	300-400 N/mm ²	GJV 300
	4.1 Temperguss (GTMW, GTMB)	Malleable cast iron (GTMW, GTMB)	400-500 N/mm ²	GJV 450
4.2 Temperguss (GTMW, GTMB)	Malleable cast iron (GTMW, GTMB)	250-500 N/mm ²	EN-GJMW-350-4 (GTW-35) EN-JM-1010	
4.2 Temperguss (GTMW, GTMB)	Malleable cast iron (GTMW, GTMB)	500-800 N/mm ²	EN-GJMB-450-6 (GTS-45) EN-JM-1140	
N	Nichteisenwerkstoffe Non-ferrous materials			
	1.1 Aluminium-Legierungen	Aluminium alloys		
	1.2 Aluminium-Knetlegierungen	Wrought aluminium alloys	≤ 200 N/mm ²	EN AW-AIMn1 EN AW-3103
	1.3 Aluminium-Knetlegierungen	Wrought aluminium alloys	≤ 350 N/mm ²	EN AW-AIMgSi EN AW-6060
	1.4 Aluminium-Knetlegierungen	Wrought aluminium alloys	≤ 550 N/mm ²	EN AW-AlZn5Mg3Cu EN AW-7022
	1.5 Aluminium-Gusslegierungen	Aluminium cast alloys	Si ≤ 7%	EN AC-AIMg5 EN AC-51300
	1.6 Aluminium-Gusslegierungen	Aluminium cast alloys	7% < Si ≤ 12%	EN AC-AISi9Cu3 EN AC-46500
	1.6 Aluminium-Gusslegierungen	Aluminium cast alloys	12% < Si ≤ 17%	GD-AISi17Cu4FeMg
	2.1 Reinkupfer, niedriglegiertes Kupfer	Pure copper, low-alloyed copper	≤ 400 N/mm ²	E-Cu 57 EN CW 004 A
	2.2 Kupfer-Zink-Legierungen (Messing, langspanend)	Copper-zinc alloys (brass, long-chipping)	≤ 550 N/mm ²	CuZn37 (Ms63) EN CW 508 L
	2.3 Kupfer-Zink-Legierungen (Messing, kurzspanend)	Copper-zinc alloys (brass, short-chipping)	≤ 550 N/mm ²	CuZn36Pb3 (Ms58) EN CW 603 N
	2.4 Kupfer-Aluminium-Legierungen (Alubronze, langspanend)	Copper-aluminium alloys (alu bronze, long-chipping)	≤ 800 N/mm ²	CuAl10Ni5Fe4 EN CW 307 G
	2.5 Kupfer-Zinn-Legierungen (Zinnbronze, langspanend)	Copper-tin alloys (tin bronze, long-chipping)	≤ 700 N/mm ²	CuSn8P EN CW 459 K
	2.6 Kupfer-Zinn-Legierungen (Zinnbronze, kurzspanend)	Copper-tin alloys (tin bronze, short-chipping)	≤ 400 N/mm ²	CuSn7 ZnPb (Rg7) 2.1090
	2.7 Kupfer-Sonderlegierungen	Special copper alloys	≤ 600 N/mm ²	(AMPCO® 8)
	2.8 Kupfer-Sonderlegierungen	Special copper alloys	≤ 1400 N/mm ²	(AMPCO® 45)
3.1 Magnesium-Knetlegierungen	Magnesium wrought alloys	≤ 500 N/mm ²	MgAl6Zn 3.5612	
3.2 Magnesium-Gusslegierungen	Magnesium cast alloys	≤ 500 N/mm ²	EN-MCMgAl9Zn1 EN-MC21120	
4.1 Duroplaste (kurzspanend)	Duroplastics (short-chipping)		Bakelit, Pertinax	
4.2 Thermoplaste (langspanend)	Thermoplastics (long-chipping)		PMMA, POM, PVC	
4.3 Faserverstärkte Kunststoffe (Faseranteil ≤ 30%)	Fibre-reinforced synthetics (fibre content ≤ 30%)		GFK, CFK, AFK	
4.4 Faserverstärkte Kunststoffe (Faseranteil > 30%)	Fibre-reinforced synthetics (fibre content > 30%)		GFK, CFK, AFK	
5.1 Grafit	Graphite		C 8000	
5.2 Wolfram-Kupfer-Legierungen	Tungsten-copper alloys		W-Cu 80/20	
5.3 Verbundwerkstoffe	Composite materials		HyLite, Alucobond	
S	Spezialwerkstoffe Special materials			
	1.1 Titan-Legierungen	Titanium alloys		
	1.2 Reintitan	Pure titanium	≤ 450 N/mm ²	Ti1 3.7025
	1.3 Titan-Legierungen	Titanium alloys	≤ 900 N/mm ²	TiAl6V4 3.7165
	1.3 Titan-Legierungen	Titanium alloys	≤ 1250 N/mm ²	TiAl4Mo4Sn2 3.7185
	2.1 Nickel-, Kobalt- und Eisen-Legierungen	Nickel alloys, cobalt alloys and iron alloys		
	2.1 Reinnickel	Pure nickel	≤ 600 N/mm ²	Ni 99.6 2.4060
	2.2 Nickel-Basis-Legierungen	Nickel-base alloys	≤ 1000 N/mm ²	Monel 400 2.4360
	2.3 Nickel-Basis-Legierungen	Nickel-base alloys	≤ 1600 N/mm ²	Inconel 718 2.4668
	2.4 Nickel-Basis-Legierungen	Nickel-base alloys	≤ 1000 N/mm ²	Udimet 605
2.5 Kobalt-Basis-Legierungen	Cobalt-base alloys	≤ 1600 N/mm ²	Haynes 25 2.4964	
2.6 Eisen-Basis-Legierungen	Iron-base alloys	≤ 1500 N/mm ²	Incoloy 800 1.4958	
H	Harte Werkstoffe Hard materials			
	1.1 Hochfeste Stähle, gehärtete Stähle, Hartguss	High strength steels, hardened steels, hard castings	44 - 50 HRC	Weldox 1100
	1.2 Hochfeste Stähle, gehärtete Stähle, Hartguss	High strength steels, hardened steels, hard castings	50 - 55 HRC	Hardox 550
	1.3 Hochfeste Stähle, gehärtete Stähle, Hartguss	High strength steels, hardened steels, hard castings	55 - 60 HRC	Armax 600T
	1.4 Hochfeste Stähle, gehärtete Stähle, Hartguss	High strength steels, hardened steels, hard castings	60 - 63 HRC	Ferro-Titanit
	1.5 Hochfeste Stähle, gehärtete Stähle, Hartguss	High strength steels, hardened steels, hard castings	63 - 66 HRC	HSSE



Allround

N						NR	N	—
3542L	3538L	3539L	3540L	3541L	3544L	3552LZ	3554LZ	9563A
8	10	12	14	16	18	20	22	24
9	11	13	15	17	19	21	23	26

Seite · Page

v_c / f_z

■	■	■	■	■	■	■	■	■	1.1	P
■	■	■	■	■	■	■	■	■	2.1	
■	■	■	■	■	■	■	■	■	3.1	
■	■	■	■	■	■	■	■	■	4.1	
■	■	■	■	■	■	■	■	■	5.1	
■	■	■	■	■	■	■	■	■	1.1	M
□	□	□	□	□	□	■	■	□	2.1	
□	□	□	□	□	□	■	■	□	3.1	
□	□	□	□	□	□	■	■	□	4.1	
■	■	■	■	■	■	■	■	■	1.1	K
■	■	■	■	■	■	■	■	■	1.2	
■	■	■	■	■	■	■	■	■	2.1	
□	□	□	□	□	□	■	■	□	2.2	
■	■	■	■	■	■	■	■	■	3.1	
■	■	■	■	■	■	■	■	■	3.2	
■	■	■	■	■	■	■	■	■	4.1	
□	□	□	□	□	□	■	■	□	4.2	
■	■	■	■	■	■	■	■	■	1.1	N
■	■	■	■	■	■	■	■	■	1.2	
■	■	■	■	■	■	■	■	■	1.3	
■	■	■	■	■	■	■	■	■	1.4	
■	■	■	■	■	■	■	■	■	1.5	
■	■	■	■	■	■	■	■	■	1.6	
■	■	■	■	■	■	■	■	■	2.1	
■	■	■	■	■	■	■	■	■	2.2	
■	■	■	■	■	■	■	■	■	2.3	
■	■	■	■	■	■	■	■	■	2.4	
■	■	■	■	■	■	■	■	■	2.5	
■	■	■	■	■	■	■	■	■	2.6	
■	■	■	■	■	■	■	■	■	2.7	
■	■	■	■	■	■	■	■	■	2.8	
■	■	■	■	■	■	■	■	■	3.1	
■	■	■	■	■	■	■	■	■	3.2	
□	□	□	□	□	□	■	■	□	4.1	
□	□	□	□	□	□	■	■	□	4.2	
□	□	□	□	□	□	■	■	□	4.3	
□	□	□	□	□	□	■	■	□	4.4	
□	□	□	□	□	□	■	■	□	5.1	
□	□	□	□	□	□	■	■	□	5.2	
□	□	□	□	□	□	■	■	□	5.3	
■	■	■	■	■	■	■	■	■	1.1	S
■	■	■	■	■	■	■	■	■	1.2	
■	■	■	■	■	■	■	■	■	1.3	
■	■	■	■	■	■	■	■	■	2.1	
□	□	□	□	□	□	■	■	□	2.2	
■	■	■	■	■	■	■	■	■	2.3	
□	□	□	□	□	□	■	■	□	2.4	
□	□	□	□	□	□	■	■	□	2.5	
□	□	□	□	□	□	■	■	□	2.6	
□	□	■	□	■	■	■	■	□	1.1	H
□	□	■	□	■	■	■	■	□	1.2	

- Hochleistungswerkzeug
- Mit 4 Schneiden
- Vibrationsarme Bearbeitung
- Hocheffiziente Schlichtbearbeitung
- Formtoleranz $\pm 0,01$ mm
- High performance tool
- With 4 flutes
- Low-vibration machining
- Highly efficient finishing
- Form tolerance ± 0.01 mm

N

HM

DIN 6535
HA
HB

Form
 $\pm 0,01$

30°

V_c / f_z
9

Optional

Tonnenform – ER
Barrel Form – ER



Allround

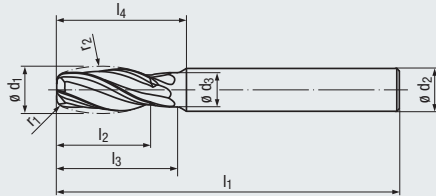
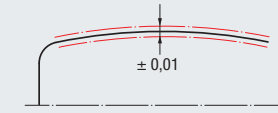

Beschichtung · Coating

Einsatzgebiete – Material (siehe Seite 6)

- Speziell für hochfeste Werkstoffe geeignet
- In fast allen Werkstoffen einsetzbar
- Zum HSC-Schlichten geeignet

Applications – material (see page 6)

- Especially suitable for high-strength materials
- For almost all materials
- Suitable for HSC finishing

ALCR

P	1.1-5.1	
M	1.1-2.1	3.1-4.1
K	1.1-2.1	2.2
K	3.1-4.1	4.2
N	1.1-1.4	
N	2.1-3.2	4.1-4.2, 5.2
S	1.1-2.2	2.3
S	2.4	2.5-2.6
H		1.1-1.2

Bestell-Code · Order code

3542L

d_1	r_1	r_2	l_2	l_3	l_1	$\varnothing d_3$	l_4	$\varnothing d_2$ h6	Z (Flutes)	Dimens.- Code
10	2	50	21	28	80	8	30	10	4	.10050A

Baumaße für Werkzeugdatenbank

Dimensions for tool database

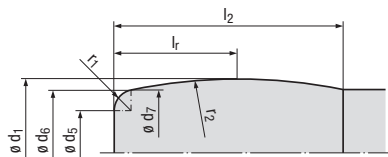

d_1	r_1	r_2	l_2	l_r	$\varnothing d_5$	$\varnothing d_6$	$\varnothing d_7$
10	2	50	21	11,747	4	7,917	8

$l_r = r_2$ trifft tangential (theoretisch) auf d_1
 r_2 is (theoretically) tangential to d_1

$d_6 =$ Tangentialpunkt von r_1 und r_2
Tangent point of r_1 and r_2

$d_7 = d_5 + 2 \times r_1$

EMUGE-FRANKEN-Werkzeuge sind bereit für Industrie 4.0.

Ab sofort steht der digitale Zwilling zu vielen unserer Katalogwerkzeuge für Sie zum Download auf unserer Homepage bereit.

EMUGE-FRANKEN tools are ready for Industry 4.0.

From now on the digital twin created for a wide variety of our catalogue tools can be downloaded directly from our homepage.

tooldata.ef-apps.de

Hartmetall-Kreissegment-Fräser mit Tonnenform – ER
 Solid carbide circle segment end mill with barrel form – ER

N



Aufmaß · Allowance
0,05 - 0,1 mm



Aufmaß · Allowance
0,1 - 0,2 mm

Gültig für · Valid for
3542L

Für die Berechnung der Drehzahl n muss mit dem Durchmesser d_1 gerechnet werden.
 In order to calculate the rotational speed n, the diameter d_1 has to be used.



	V_c [m/min]	f_z [mm]	V_c [m/min]	f_z [mm]			MMS MQL		
P	1.1	420	$0,004 \times d_1$	420	$0,003 \times d_1$	<input type="checkbox"/>	<input checked="" type="checkbox"/>	<input type="checkbox"/>	<input checked="" type="checkbox"/>
	2.1	375	$0,004 \times d_1$	375	$0,003 \times d_1$	<input type="checkbox"/>	<input checked="" type="checkbox"/>	<input type="checkbox"/>	<input checked="" type="checkbox"/>
	3.1	315	$0,003 \times d_1$	315	$0,003 \times d_1$	<input type="checkbox"/>	<input checked="" type="checkbox"/>	<input type="checkbox"/>	<input checked="" type="checkbox"/>
	4.1	300	$0,003 \times d_1$	300	$0,002 \times d_1$	<input type="checkbox"/>	<input checked="" type="checkbox"/>		
	5.1	270	$0,003 \times d_1$	270	$0,002 \times d_1$	<input type="checkbox"/>	<input checked="" type="checkbox"/>		
M	1.1	150	$0,005 \times d_1$	150	$0,003 \times d_1$			<input type="checkbox"/>	<input checked="" type="checkbox"/>
	2.1	120	$0,005 \times d_1$	120	$0,003 \times d_1$			<input type="checkbox"/>	<input checked="" type="checkbox"/>
	3.1	90	$0,004 \times d_1$	90	$0,002 \times d_1$			<input type="checkbox"/>	<input checked="" type="checkbox"/>
	4.1	60	$0,004 \times d_1$	60	$0,002 \times d_1$			<input type="checkbox"/>	<input checked="" type="checkbox"/>
K	1.1	280	$0,005 \times d_1$	280	$0,004 \times d_1$	<input type="checkbox"/>	<input checked="" type="checkbox"/>		
	1.2	280	$0,005 \times d_1$	280	$0,004 \times d_1$	<input type="checkbox"/>	<input checked="" type="checkbox"/>		
	2.1	250	$0,004 \times d_1$	250	$0,003 \times d_1$	<input type="checkbox"/>	<input checked="" type="checkbox"/>		
	2.2	250	$0,004 \times d_1$	250	$0,003 \times d_1$	<input type="checkbox"/>	<input checked="" type="checkbox"/>		
	3.1	210	$0,004 \times d_1$	210	$0,003 \times d_1$	<input type="checkbox"/>	<input checked="" type="checkbox"/>		
	3.2	210	$0,004 \times d_1$	210	$0,003 \times d_1$	<input type="checkbox"/>	<input checked="" type="checkbox"/>		
	4.1	180	$0,003 \times d_1$	180	$0,002 \times d_1$	<input type="checkbox"/>	<input checked="" type="checkbox"/>		
	4.2	140	$0,003 \times d_1$	140	$0,002 \times d_1$	<input type="checkbox"/>	<input checked="" type="checkbox"/>		
N	1.1	600	$0,004 \times d_1$	600	$0,003 \times d_1$			<input type="checkbox"/>	<input checked="" type="checkbox"/>
	1.2	600	$0,004 \times d_1$	600	$0,003 \times d_1$			<input type="checkbox"/>	<input checked="" type="checkbox"/>
	1.3	600	$0,003 \times d_1$	600	$0,002 \times d_1$			<input type="checkbox"/>	<input checked="" type="checkbox"/>
	1.4	410	$0,004 \times d_1$	410	$0,003 \times d_1$			<input type="checkbox"/>	<input checked="" type="checkbox"/>
	1.5								
	1.6								
	2.1	270	$0,005 \times d_1$	270	$0,004 \times d_1$			<input type="checkbox"/>	<input checked="" type="checkbox"/>
	2.2	270	$0,005 \times d_1$	270	$0,004 \times d_1$			<input type="checkbox"/>	<input checked="" type="checkbox"/>
	2.3	270	$0,005 \times d_1$	270	$0,004 \times d_1$		<input type="checkbox"/>	<input type="checkbox"/>	<input checked="" type="checkbox"/>
	2.4	255	$0,004 \times d_1$	255	$0,003 \times d_1$		<input type="checkbox"/>	<input type="checkbox"/>	<input checked="" type="checkbox"/>
	2.5	255	$0,004 \times d_1$	255	$0,003 \times d_1$		<input type="checkbox"/>	<input type="checkbox"/>	<input checked="" type="checkbox"/>
	2.6	255	$0,004 \times d_1$	255	$0,003 \times d_1$		<input type="checkbox"/>	<input type="checkbox"/>	<input checked="" type="checkbox"/>
	2.7	150	$0,003 \times d_1$	150	$0,002 \times d_1$		<input type="checkbox"/>	<input type="checkbox"/>	<input checked="" type="checkbox"/>
	2.8	150	$0,003 \times d_1$	150	$0,002 \times d_1$		<input type="checkbox"/>	<input type="checkbox"/>	<input checked="" type="checkbox"/>
	3.1	410	$0,005 \times d_1$	410	$0,004 \times d_1$			<input type="checkbox"/>	<input checked="" type="checkbox"/>
	3.2	410	$0,005 \times d_1$	410	$0,004 \times d_1$			<input type="checkbox"/>	<input checked="" type="checkbox"/>
4.1	410	$0,005 \times d_1$	410	$0,004 \times d_1$		<input type="checkbox"/>	<input type="checkbox"/>	<input checked="" type="checkbox"/>	
4.2	600	$0,005 \times d_1$	600	$0,004 \times d_1$			<input type="checkbox"/>	<input checked="" type="checkbox"/>	
4.3									
4.4									
5.1									
5.2	150	$0,005 \times d_1$	150	$0,003 \times d_1$				<input checked="" type="checkbox"/>	
5.3									
S	1.1	100	$0,006 \times d_1$	100	$0,004 \times d_1$				<input checked="" type="checkbox"/>
	1.2	80	$0,005 \times d_1$	80	$0,003 \times d_1$				<input checked="" type="checkbox"/>
	1.3	60	$0,005 \times d_1$	60	$0,003 \times d_1$				<input checked="" type="checkbox"/>
	2.1	80	$0,004 \times d_1$	80	$0,002 \times d_1$				<input checked="" type="checkbox"/>
	2.2	30	$0,004 \times d_1$	30	$0,002 \times d_1$				<input checked="" type="checkbox"/>
	2.3	30	$0,004 \times d_1$	30	$0,002 \times d_1$				<input checked="" type="checkbox"/>
2.4	30	$0,004 \times d_1$	30	$0,002 \times d_1$				<input checked="" type="checkbox"/>	
2.5	30	$0,004 \times d_1$	30	$0,002 \times d_1$				<input checked="" type="checkbox"/>	
2.6	30	$0,004 \times d_1$	30	$0,002 \times d_1$				<input checked="" type="checkbox"/>	
H	1.1	130	$0,005 \times d_1$	130	$0,003 \times d_1$	<input type="checkbox"/>	<input checked="" type="checkbox"/>		
	1.2	100	$0,005 \times d_1$	100	$0,003 \times d_1$	<input type="checkbox"/>	<input checked="" type="checkbox"/>		
	1.3								
	1.4								
	1.5								

v_c = Schnittgeschwindigkeit · Cutting speed
 f_z = Vorschub pro Zahn · Feed per tooth

= sehr gut geeignet · very suitable
 = gut geeignet · suitable

- Hochleistungswerkzeug
- Mit 3 oder 4 Schneiden
- Vibrationsarme Bearbeitung
- Hocheffiziente Schlichtbearbeitung
- Formtoleranz $\pm 0,01$ mm
- High performance tool
- With 3 or 4 flutes
- Low-vibration machining
- Highly efficient finishing
- Form tolerance ± 0.01 mm

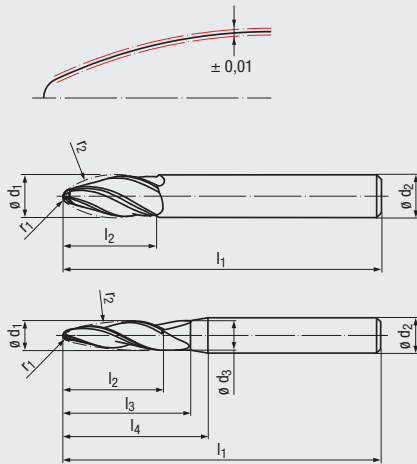

N

HM

DIN 6535
HA
HB

Form
 $\pm 0,01$

30°

V_c/f_z
11

Optional

Tropfenform – VR Oval Form – VR



Allround

Beschichtung · Coating

Einsatzgebiete – Material (siehe Seite 6)

- Speziell für hochfeste Werkstoffe geeignet
- In fast allen Werkstoffen einsetzbar
- Zum HSC-Schlichten geeignet

Applications – material (see page 6)

- Especially suitable for high-strength materials
- For almost all materials
- Suitable for HSC finishing

ALCR

P	1.1-5.1	
M	1.1-2.1	3.1-4.1
K	1.1-2.1	2.2
K	3.1-4.1	4.2
N	1.1-1.4	
N	2.1-3.2	4.1-4.2, 5.2
S	1.1-2.2	2.3
S	2.4	2.5-2.6
H		1.1-1.2

Bestell-Code · Order code

3538L

d ₁	r ₁	r ₂	l ₂	l ₃	l ₁	∅ d ₃	l ₄	∅ d ₂ h ₆	Z (Flutes)	Dimens.- Code			
3	0,75	50	11	14	62	3	25	6	3	.03050A	●	new	
4	0,75	60	14	18	62	4	25	6	3	.04060A	●	new	
5	1	75	17	22	62	5	25	6	3	.05075A	●	new	
6	1	95	22	–	62	–	–	6	3	.06095A	●		
8	1	90	25	–	68	–	–	8	3	.08090A	●		
10	2	85	26	–	72	–	–	10	4	.10085A	●		
12	2	80	28	–	83	–	–	12	4	.12080A	●		
16	3	75	31	–	92	–	–	16	4	.16075A	●		

Bearbeitungsbeispiel

Bauteil: Flansch einer Treibstoffleitung aus der Luftfahrtindustrie

Anwendung: Schlichtbearbeitung der runden Innenkontur sowie Teile der Außenkontur

Machining example

Component: Flange of a fuel pipe from the aviation industry

Application: Finishing of the round inner contour and parts of the outer contour



Hartmetall-Kreissegment-Fräser mit Tropfenform – VR
Solid carbide circle segment end mills with oval form – VR

N



Aufmaß · Allowance
0,05 - 0,1 mm



Aufmaß · Allowance
0,1 - 0,2 mm



Aufmaß · Allowance
0,2 - 0,3 mm

Gültig für · Valid for
3538L

Für die Berechnung der Drehzahl n muss mit dem Durchmesser d₁ gerechnet werden.

In order to calculate the rotational speed n, the diameter d₁ has to be used.



		Aufmaß 0,05 - 0,1 mm		Aufmaß 0,1 - 0,2 mm		Aufmaß 0,2 - 0,3 mm		Coolant	MMS MQL	Chip
		V _c [m/min]	f _z [mm]	V _c [m/min]	f _z [mm]	V _c [m/min]	f _z [mm]			
P	1.1	420	0,004 x d ₁	420	0,003 x d ₁	420	0,003 x d ₁	☐	■	☐
	2.1	375	0,004 x d ₁	375	0,003 x d ₁	375	0,003 x d ₁	☐	■	☐
	3.1	315	0,003 x d ₁	315	0,003 x d ₁	315	0,002 x d ₁	☐	■	☐
	4.1	300	0,003 x d ₁	300	0,002 x d ₁	300	0,002 x d ₁	☐	■	
	5.1	270	0,003 x d ₁	270	0,002 x d ₁	270	0,002 x d ₁	☐	■	
M	1.1	150	0,005 x d ₁	150	0,004 x d ₁	150	0,003 x d ₁			☐
	2.1	120	0,005 x d ₁	120	0,004 x d ₁	120	0,003 x d ₁			☐
	3.1	90	0,004 x d ₁	90	0,003 x d ₁	90	0,002 x d ₁			☐
	4.1	60	0,004 x d ₁	60	0,003 x d ₁	60	0,002 x d ₁			☐
K	1.1	280	0,005 x d ₁	280	0,004 x d ₁	280	0,003 x d ₁	☐	■	
	1.2	280	0,005 x d ₁	280	0,004 x d ₁	280	0,003 x d ₁	☐	■	
	2.1	250	0,004 x d ₁	250	0,003 x d ₁	250	0,003 x d ₁	☐	■	
	2.2	250	0,004 x d ₁	250	0,003 x d ₁	250	0,003 x d ₁	☐	■	
	3.1	210	0,004 x d ₁	210	0,003 x d ₁	210	0,003 x d ₁	☐	■	
	3.2	210	0,004 x d ₁	210	0,003 x d ₁	210	0,003 x d ₁	☐	■	
	4.1	180	0,003 x d ₁	180	0,002 x d ₁	180	0,002 x d ₁	☐	■	
	4.2	140	0,003 x d ₁	140	0,002 x d ₁	140	0,002 x d ₁	☐	■	
N	1.1	600	0,004 x d ₁	600	0,003 x d ₁	600	0,003 x d ₁			☐
	1.2	600	0,004 x d ₁	600	0,003 x d ₁	600	0,003 x d ₁			☐
	1.3	600	0,003 x d ₁	600	0,002 x d ₁	600	0,002 x d ₁			☐
	1.4	410	0,004 x d ₁	410	0,003 x d ₁	410	0,003 x d ₁			☐
	1.5									
	1.6									
	2.1	270	0,005 x d ₁	270	0,004 x d ₁	270	0,003 x d ₁			☐
	2.2	270	0,005 x d ₁	270	0,004 x d ₁	270	0,003 x d ₁			☐
	2.3	270	0,005 x d ₁	270	0,004 x d ₁	270	0,003 x d ₁			☐
	2.4	255	0,004 x d ₁	255	0,003 x d ₁	255	0,003 x d ₁	☐	■	☐
	2.5	255	0,004 x d ₁	255	0,003 x d ₁	255	0,003 x d ₁			☐
	2.6	255	0,004 x d ₁	255	0,003 x d ₁	255	0,003 x d ₁			☐
	2.7	150	0,003 x d ₁	150	0,002 x d ₁	150	0,002 x d ₁	☐	■	☐
	2.8	150	0,003 x d ₁	150	0,002 x d ₁	150	0,002 x d ₁			☐
	3.1	410	0,005 x d ₁	410	0,004 x d ₁	410	0,003 x d ₁			☐
	3.2	410	0,005 x d ₁	410	0,004 x d ₁	410	0,003 x d ₁			☐
4.1	410	0,005 x d ₁	410	0,004 x d ₁	410	0,003 x d ₁	☐	■	☐	
4.2	600	0,005 x d ₁	600	0,004 x d ₁	600	0,003 x d ₁			☐	
4.3										
4.4										
5.1										
5.2	150	0,005 x d ₁	150	0,004 x d ₁	150	0,003 x d ₁			■	
5.3										
S	1.1	100	0,006 x d ₁	100	0,005 x d ₁	100	0,004 x d ₁			■
	1.2	80	0,005 x d ₁	80	0,004 x d ₁	80	0,003 x d ₁			■
	1.3	60	0,005 x d ₁	60	0,004 x d ₁	60	0,003 x d ₁			■
	2.1	80	0,004 x d ₁	80	0,003 x d ₁	80	0,002 x d ₁			■
	2.2	30	0,004 x d ₁	30	0,003 x d ₁	30	0,002 x d ₁			■
	2.3	30	0,004 x d ₁	30	0,003 x d ₁	30	0,002 x d ₁			■
	2.4	30	0,004 x d ₁	30	0,003 x d ₁	30	0,002 x d ₁			■
	2.5	30	0,004 x d ₁	30	0,003 x d ₁	30	0,002 x d ₁			■
2.6	30	0,004 x d ₁	30	0,003 x d ₁	30	0,002 x d ₁			■	
H	1.1	130	0,005 x d ₁	130	0,004 x d ₁	130	0,003 x d ₁	☐	■	
	1.2	100	0,005 x d ₁	100	0,004 x d ₁	100	0,003 x d ₁	☐	■	
	1.3									
	1.4									
	1.5									

v_c = Schnittgeschwindigkeit · Cutting speed
f_z = Vorschub pro Zahn · Feed per tooth

■ = sehr gut geeignet · very suitable
☐ = gut geeignet · suitable

- Hochleistungswerkzeug
- Mit 6 Schneiden
- Vibrationsarme Bearbeitung
- Hocheffiziente Schlichtbearbeitung
- Formtoleranz $\pm 0,01$ mm
- High performance tool
- With 6 flutes
- Low-vibration machining
- Highly efficient finishing
- Form tolerance ± 0.01 mm

N

HM

DIN 6535
HA
HB

Form
 $\pm 0,01$

30°

V_c / f_z
13

Optional

≤ 60
HRC

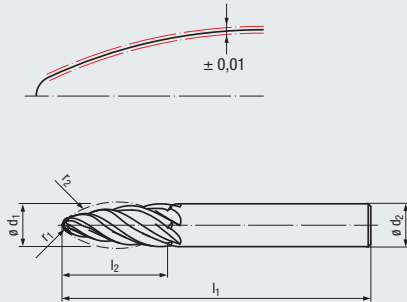

Tropfenform – VR
Oval Form – VR



Allround

Beschichtung · Coating

Einsatzgebiete – Material (siehe Seite 6)

- Speziell für hochfeste Werkstoffe geeignet
- In fast allen Werkstoffen einsetzbar
- Hartbearbeitung bis 60 HRC möglich
- Zum HSC-Schlichten geeignet

Applications – material (see page 6)

- Especially suitable for high-strength materials
- For almost all materials
- Hard machining of up to 60 HRC
- Suitable for HSC finishing

ALCR

P	1.1-5.1	
M	1.1-2.1	3.1-4.1
K	1.1-2.1	2.2
K	3.1-4.1	4.2
N	1.1-1.4	
N	2.1-3.2	4.1-4.2, 5.2
S	1.1-2.2	2.3
S	2.4	2.5-2.6
H	1.1-1.3	

Bestell-Code · Order code

3539L

d_1	r_1	r_2	l_2	l_1	$\varnothing d_2$ h6	Z (Flutes)	Dimens.- Code			
10	2	85	26	72	10	6	.10085A	●		
12	2	80	28	83	12	6	.12080A	●		
16	3	75	31	92	16	6	.16075A	●		

Bearbeitungsbeispiel

Bauteil: Lagerbock aus dem Maschinenbau

Anwendung: Komplette Schlichtbearbeitung der Außenkontur, Innenkontur und der Taschen

Machining example

Component: Bearing block from mechanical engineering

Application: Complete finishing of the the outer contour, inner contour and the pockets

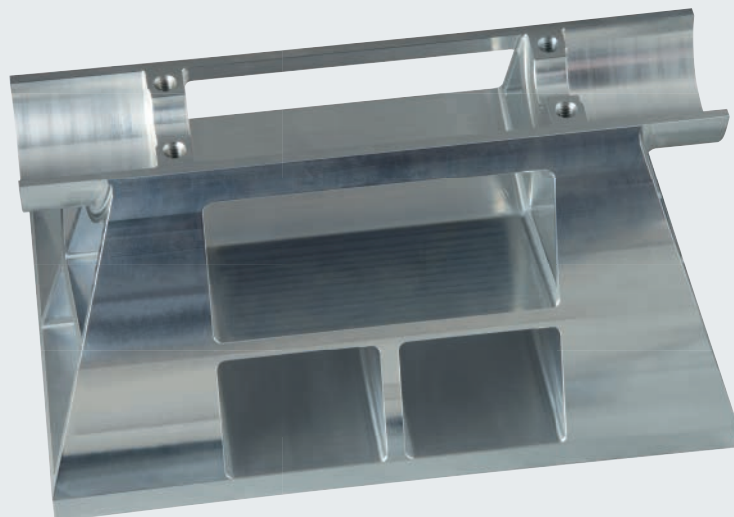

Hartmetall-Kreissegment-Fräser mit Tropfenform – VR
Solid carbide circle segment end mills with oval form – VR

N



Aufmaß · Allowance
0,05 - 0,1 mm



Aufmaß · Allowance
0,1 - 0,2 mm

Gültig für · Valid for
3539L

Für die Berechnung der Drehzahl n muss mit dem Durchmesser d_1 gerechnet werden.

In order to calculate the rotational speed n, the diameter d_1 has to be used.



	V_c [m/min]	f_z [mm]	V_c [m/min]	f_z [mm]			MMS MQL	
P	1.1	$0,003 \times d_1$	420	$0,002 \times d_1$	<input type="checkbox"/>	<input checked="" type="checkbox"/>	<input type="checkbox"/>	<input checked="" type="checkbox"/>
	2.1	$0,003 \times d_1$	375	$0,002 \times d_1$	<input type="checkbox"/>	<input checked="" type="checkbox"/>	<input type="checkbox"/>	<input checked="" type="checkbox"/>
	3.1	$0,002 \times d_1$	315	$0,002 \times d_1$	<input type="checkbox"/>	<input checked="" type="checkbox"/>	<input type="checkbox"/>	<input checked="" type="checkbox"/>
	4.1	$0,002 \times d_1$	300	$0,001 \times d_1$	<input type="checkbox"/>	<input checked="" type="checkbox"/>	<input type="checkbox"/>	<input type="checkbox"/>
	5.1	$0,002 \times d_1$	270	$0,001 \times d_1$	<input type="checkbox"/>	<input checked="" type="checkbox"/>	<input type="checkbox"/>	<input type="checkbox"/>
M	1.1	$0,003 \times d_1$	150	$0,002 \times d_1$			<input type="checkbox"/>	<input checked="" type="checkbox"/>
	2.1	$0,003 \times d_1$	120	$0,002 \times d_1$			<input type="checkbox"/>	<input checked="" type="checkbox"/>
	3.1	$0,002 \times d_1$	90	$0,001 \times d_1$			<input type="checkbox"/>	<input checked="" type="checkbox"/>
	4.1	$0,002 \times d_1$	60	$0,001 \times d_1$			<input type="checkbox"/>	<input checked="" type="checkbox"/>
K	1.1	$0,004 \times d_1$	280	$0,003 \times d_1$	<input type="checkbox"/>	<input checked="" type="checkbox"/>		<input type="checkbox"/>
	1.2	$0,004 \times d_1$	280	$0,003 \times d_1$	<input type="checkbox"/>	<input checked="" type="checkbox"/>		<input type="checkbox"/>
	2.1	$0,003 \times d_1$	250	$0,002 \times d_1$	<input type="checkbox"/>	<input checked="" type="checkbox"/>		<input type="checkbox"/>
	2.2	$0,003 \times d_1$	250	$0,002 \times d_1$	<input type="checkbox"/>	<input checked="" type="checkbox"/>		<input type="checkbox"/>
	3.1	$0,003 \times d_1$	210	$0,002 \times d_1$	<input type="checkbox"/>	<input checked="" type="checkbox"/>		<input type="checkbox"/>
	3.2	$0,003 \times d_1$	210	$0,002 \times d_1$	<input type="checkbox"/>	<input checked="" type="checkbox"/>		<input type="checkbox"/>
	4.1	$0,002 \times d_1$	180	$0,001 \times d_1$	<input type="checkbox"/>	<input checked="" type="checkbox"/>		<input type="checkbox"/>
	4.2	$0,002 \times d_1$	140	$0,001 \times d_1$	<input type="checkbox"/>	<input checked="" type="checkbox"/>		<input type="checkbox"/>
N	1.1	$0,003 \times d_1$	600	$0,002 \times d_1$			<input type="checkbox"/>	<input checked="" type="checkbox"/>
	1.2	$0,003 \times d_1$	600	$0,002 \times d_1$			<input type="checkbox"/>	<input checked="" type="checkbox"/>
	1.3	$0,002 \times d_1$	600	$0,001 \times d_1$			<input type="checkbox"/>	<input checked="" type="checkbox"/>
	1.4	$0,003 \times d_1$	410	$0,002 \times d_1$			<input type="checkbox"/>	<input checked="" type="checkbox"/>
	1.5							
	1.6							
	2.1	$0,004 \times d_1$	270	$0,003 \times d_1$			<input type="checkbox"/>	<input checked="" type="checkbox"/>
	2.2	$0,004 \times d_1$	270	$0,003 \times d_1$			<input type="checkbox"/>	<input checked="" type="checkbox"/>
	2.3	$0,004 \times d_1$	270	$0,003 \times d_1$		<input type="checkbox"/>	<input type="checkbox"/>	<input checked="" type="checkbox"/>
	2.4	$0,003 \times d_1$	255	$0,002 \times d_1$		<input type="checkbox"/>	<input type="checkbox"/>	<input checked="" type="checkbox"/>
	2.5	$0,003 \times d_1$	255	$0,002 \times d_1$		<input type="checkbox"/>	<input type="checkbox"/>	<input checked="" type="checkbox"/>
	2.6	$0,003 \times d_1$	255	$0,002 \times d_1$		<input type="checkbox"/>	<input type="checkbox"/>	<input checked="" type="checkbox"/>
	2.7	$0,002 \times d_1$	150	$0,001 \times d_1$		<input type="checkbox"/>	<input type="checkbox"/>	<input checked="" type="checkbox"/>
	2.8	$0,002 \times d_1$	150	$0,001 \times d_1$		<input type="checkbox"/>	<input type="checkbox"/>	<input checked="" type="checkbox"/>
	3.1	$0,004 \times d_1$	410	$0,003 \times d_1$			<input type="checkbox"/>	<input checked="" type="checkbox"/>
	3.2	$0,004 \times d_1$	410	$0,003 \times d_1$			<input type="checkbox"/>	<input checked="" type="checkbox"/>
4.1	$0,004 \times d_1$	410	$0,003 \times d_1$		<input type="checkbox"/>	<input type="checkbox"/>	<input checked="" type="checkbox"/>	
4.2	$0,004 \times d_1$	600	$0,003 \times d_1$		<input type="checkbox"/>	<input type="checkbox"/>	<input checked="" type="checkbox"/>	
4.3								
4.4								
5.1								
5.2	$0,003 \times d_1$	150	$0,002 \times d_1$				<input checked="" type="checkbox"/>	
5.3								
S	1.1	$0,005 \times d_1$	100	$0,004 \times d_1$				<input checked="" type="checkbox"/>
	1.2	$0,004 \times d_1$	80	$0,003 \times d_1$				<input checked="" type="checkbox"/>
	1.3	$0,004 \times d_1$	60	$0,003 \times d_1$				<input checked="" type="checkbox"/>
	2.1	$0,003 \times d_1$	80	$0,002 \times d_1$				<input checked="" type="checkbox"/>
	2.2	$0,003 \times d_1$	30	$0,002 \times d_1$				<input checked="" type="checkbox"/>
	2.3	$0,003 \times d_1$	30	$0,002 \times d_1$				<input checked="" type="checkbox"/>
	2.4	$0,003 \times d_1$	30	$0,002 \times d_1$				<input checked="" type="checkbox"/>
	2.5	$0,003 \times d_1$	30	$0,002 \times d_1$				<input checked="" type="checkbox"/>
2.6	$0,003 \times d_1$	30	$0,002 \times d_1$				<input checked="" type="checkbox"/>	
H	1.1	$0,004 \times d_1$	130	$0,003 \times d_1$	<input type="checkbox"/>	<input checked="" type="checkbox"/>		<input type="checkbox"/>
	1.2	$0,004 \times d_1$	100	$0,003 \times d_1$	<input type="checkbox"/>	<input checked="" type="checkbox"/>		<input type="checkbox"/>
	1.3	$0,003 \times d_1$	80	$0,002 \times d_1$	<input type="checkbox"/>	<input checked="" type="checkbox"/>		<input type="checkbox"/>
	1.4							
	1.5							

v_c = Schnittgeschwindigkeit · Cutting speed
 f_z = Vorschub pro Zahn · Feed per tooth

= sehr gut geeignet · very suitable
 = gut geeignet · suitable

- Hochleistungswerkzeug
- Mit 2 oder 3 Schneiden
- Vibrationsarme Bearbeitung
- Hocheffiziente Schlichtbearbeitung
- Formtoleranz $\pm 0,01$ mm
- High performance tool
- With 2 or 3 flutes
- Low-vibration machining
- Highly efficient finishing
- Form tolerance ± 0.01 mm

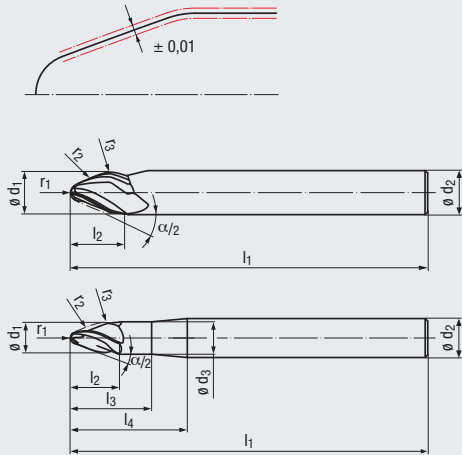

N

HM

DIN 6535
HA
HB

Form $\pm 0,01$

20-30°

V_c / f_z
15

Optional

Kegelform – VR Taper Form – VR

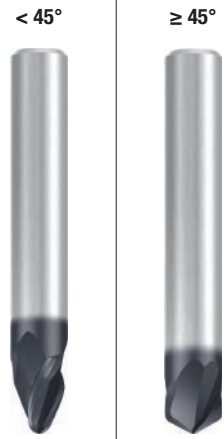

Allround

Beschichtung · Coating

Einsatzgebiete – Material (siehe Seite 6)

- Speziell für hochfeste Werkstoffe geeignet
- In fast allen Werkstoffen einsetzbar
- Zum HSC-Schlichten geeignet

Applications – material (see page 6)

- Especially suitable for high-strength materials
- For almost all materials
- Suitable for HSC finishing

ALCR

P	1.1-5.1	
M	1.1-2.1	3.1-4.1
K	1.1-2.1	2.2
K	3.1-4.1	4.2
N	1.1-1.4	
N	2.1-3.2	4.1-4.2, 5.2
S	1.1-2.2	2.3
S	2.4	2.5-2.6
H		1.1-1.2

Bestell-Code · Order code

$\alpha/2$	$\varnothing d_1$	r_1	r_2	r_3	l_2	l_3	l_1	$\varnothing d_3$	l_4	$\varnothing d_2$	Z h6 (Flutes)	Dimens.- Code	3540L			
12,5°	16	2	1000	5	31	-	108	-	-	16	3	.1610AA	●			
	16	4	1000	5	24	-	108	-	-	16	3	.1610AB	●			
17,5°	3	0,75	50	1,5	4	7	62	3	14	6	3	.03050A	●	new		
	4	0,75	125	2	5,5	9,5	62	4	18	6	3	.04125A	●	new		
	5	1	150	2,5	7,5	12,5	62	5	18	6	3	.05150A	●	new		
	6	1	250	3	9,5	-	62	-	-	6	3	.06250A	●			
20°	8	1,5	250	4	10,5	-	68	-	-	8	3	.08250A	●			
	10	2	250	5	12,5	-	80	-	-	10	3	.10250A	●			
	12	3	250	6	13,5	-	93	-	-	12	3	.12250A	●			
	16	4	500	8	18,5	-	108	-	-	16	3	.16500A	●			
	16	4	1500	8	18,5	-	108	-	-	16	3	.1615AA	●			
42,5°	12	1	200	1	8	-	93	-	-	12	3	.12200A	●			
60°	10	1	200	1,5	6	-	80	-	-	10	2	.10200A			●	
70°	10	1	200	2	6	-	80	-	-	10	2	.10200B			●	

Nur mit Anstellwinkel $\alpha/2$ einsetzen!
Only use with tilt angle $\alpha/2$!

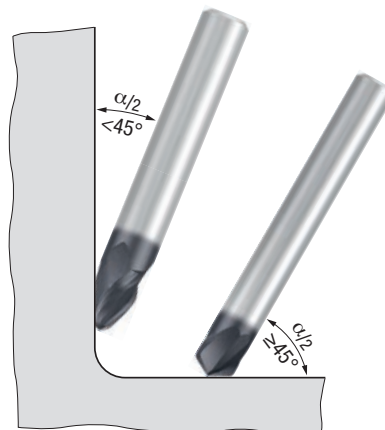

Hartmetall-Kreissegment-Fräser mit Kegelform – VR
Solid carbide circle segment end mills with taper form – VR

N

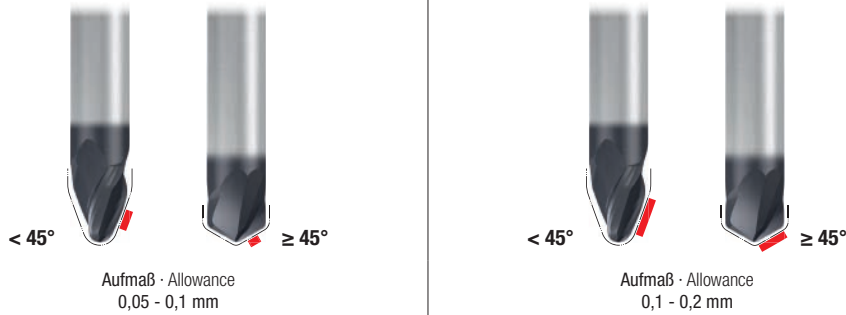

Gültig für · Valid for
3540L

Für die Berechnung der Drehzahl n muss mit dem Durchmesser d_1 gerechnet werden.
In order to calculate the rotational speed n, the diameter d_1 has to be used.



	V_c [m/min]	f_z [mm]	V_c [m/min]	f_z [mm]			
P	1.1	$0,004 \times d_1$	420	$0,003 \times d_1$	<input type="checkbox"/>	<input checked="" type="checkbox"/>	<input type="checkbox"/>
	2.1	$0,004 \times d_1$	375	$0,003 \times d_1$	<input type="checkbox"/>	<input checked="" type="checkbox"/>	<input type="checkbox"/>
	3.1	$0,003 \times d_1$	315	$0,003 \times d_1$	<input type="checkbox"/>	<input checked="" type="checkbox"/>	<input type="checkbox"/>
	4.1	$0,003 \times d_1$	300	$0,002 \times d_1$	<input type="checkbox"/>	<input checked="" type="checkbox"/>	<input type="checkbox"/>
	5.1	$0,003 \times d_1$	270	$0,002 \times d_1$	<input type="checkbox"/>	<input checked="" type="checkbox"/>	<input type="checkbox"/>
M	1.1	$0,004 \times d_1$	150	$0,003 \times d_1$			<input type="checkbox"/>
	2.1	$0,004 \times d_1$	120	$0,003 \times d_1$			<input type="checkbox"/>
	3.1	$0,003 \times d_1$	90	$0,002 \times d_1$			<input type="checkbox"/>
	4.1	$0,003 \times d_1$	60	$0,002 \times d_1$			<input type="checkbox"/>
K	1.1	$0,007 \times d_1$	280	$0,004 \times d_1$	<input type="checkbox"/>	<input checked="" type="checkbox"/>	<input type="checkbox"/>
	1.2	$0,007 \times d_1$	280	$0,004 \times d_1$	<input type="checkbox"/>	<input checked="" type="checkbox"/>	<input type="checkbox"/>
	2.1	$0,006 \times d_1$	250	$0,003 \times d_1$	<input type="checkbox"/>	<input checked="" type="checkbox"/>	<input type="checkbox"/>
	2.2	$0,006 \times d_1$	250	$0,003 \times d_1$	<input type="checkbox"/>	<input checked="" type="checkbox"/>	<input type="checkbox"/>
	3.1	$0,006 \times d_1$	210	$0,003 \times d_1$	<input type="checkbox"/>	<input checked="" type="checkbox"/>	<input type="checkbox"/>
	3.2	$0,006 \times d_1$	210	$0,003 \times d_1$	<input type="checkbox"/>	<input checked="" type="checkbox"/>	<input type="checkbox"/>
	4.1	$0,004 \times d_1$	180	$0,002 \times d_1$	<input type="checkbox"/>	<input checked="" type="checkbox"/>	<input type="checkbox"/>
	4.2	$0,003 \times d_1$	140	$0,002 \times d_1$	<input type="checkbox"/>	<input checked="" type="checkbox"/>	<input type="checkbox"/>
N	1.1	$0,004 \times d_1$	600	$0,003 \times d_1$			<input type="checkbox"/>
	1.2	$0,004 \times d_1$	600	$0,003 \times d_1$			<input type="checkbox"/>
	1.3	$0,003 \times d_1$	600	$0,002 \times d_1$			<input type="checkbox"/>
	1.4	$0,004 \times d_1$	410	$0,003 \times d_1$			<input type="checkbox"/>
	1.5						
	1.6						
	2.1	$0,005 \times d_1$	270	$0,004 \times d_1$			<input type="checkbox"/>
	2.2	$0,005 \times d_1$	270	$0,004 \times d_1$			<input type="checkbox"/>
	2.3	$0,005 \times d_1$	270	$0,004 \times d_1$	<input type="checkbox"/>	<input type="checkbox"/>	<input type="checkbox"/>
	2.4	$0,004 \times d_1$	255	$0,003 \times d_1$		<input type="checkbox"/>	<input type="checkbox"/>
	2.5	$0,004 \times d_1$	255	$0,003 \times d_1$		<input type="checkbox"/>	<input type="checkbox"/>
	2.6	$0,004 \times d_1$	255	$0,003 \times d_1$	<input type="checkbox"/>	<input type="checkbox"/>	<input type="checkbox"/>
	2.7	$0,003 \times d_1$	150	$0,002 \times d_1$		<input type="checkbox"/>	<input type="checkbox"/>
	2.8	$0,003 \times d_1$	150	$0,002 \times d_1$		<input type="checkbox"/>	<input type="checkbox"/>
	3.1	$0,005 \times d_1$	410	$0,004 \times d_1$			<input type="checkbox"/>
	3.2	$0,005 \times d_1$	410	$0,004 \times d_1$			<input type="checkbox"/>
4.1	$0,005 \times d_1$	410	$0,004 \times d_1$		<input type="checkbox"/>	<input type="checkbox"/>	
4.2	$0,005 \times d_1$	600	$0,004 \times d_1$		<input type="checkbox"/>	<input type="checkbox"/>	
4.3							
4.4							
5.1							
5.2	$0,004 \times d_1$	150	$0,003 \times d_1$			<input type="checkbox"/>	
5.3							
S	1.1	$0,005 \times d_1$	100	$0,004 \times d_1$			<input type="checkbox"/>
	1.2	$0,004 \times d_1$	80	$0,003 \times d_1$			<input type="checkbox"/>
	1.3	$0,004 \times d_1$	60	$0,003 \times d_1$			<input type="checkbox"/>
	2.1	$0,003 \times d_1$	80	$0,002 \times d_1$			<input type="checkbox"/>
	2.2	$0,003 \times d_1$	30	$0,002 \times d_1$			<input type="checkbox"/>
	2.3	$0,003 \times d_1$	30	$0,002 \times d_1$			<input type="checkbox"/>
	2.4	$0,003 \times d_1$	30	$0,002 \times d_1$			<input type="checkbox"/>
2.5	$0,003 \times d_1$	30	$0,002 \times d_1$			<input type="checkbox"/>	
2.6	$0,003 \times d_1$	30	$0,002 \times d_1$			<input type="checkbox"/>	
H	1.1	$0,005 \times d_1$	130	$0,003 \times d_1$	<input type="checkbox"/>	<input checked="" type="checkbox"/>	<input type="checkbox"/>
	1.2	$0,005 \times d_1$	100	$0,003 \times d_1$	<input type="checkbox"/>	<input checked="" type="checkbox"/>	<input type="checkbox"/>
	1.3						
	1.4						
	1.5						

v_c = Schnittgeschwindigkeit · Cutting speed
 f_z = Vorschub pro Zahn · Feed per tooth

= sehr gut geeignet · very suitable
 = gut geeignet · suitable

- Hochleistungswerkzeug
- Mit 4 oder 6 Schneiden
- Vibrationsarme Bearbeitung
- Hocheffiziente Schlichtbearbeitung
- Formtoleranz $\pm 0,01$ mm

- High performance tool
- With 4 or 6 flutes
- Low-vibration machining
- Highly efficient finishing
- Form tolerance ± 0.01 mm

N

HM

DIN 6535
HA
HB

Form
 $\pm 0,01$

20-30°

V_c / f_z
17

Optional

≤ 60
HRC

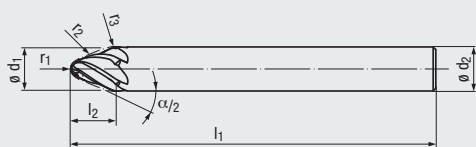
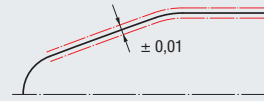

Kegelform – VR
Taper Form – VR

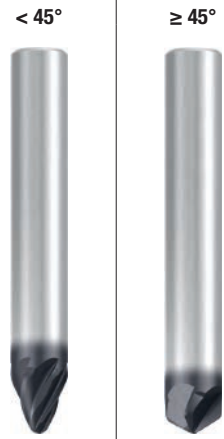

Allround

Beschichtung · Coating

Einsatzgebiete – Material (siehe Seite 6)

- Speziell für hochfeste Werkstoffe geeignet
- In fast allen Werkstoffen einsetzbar
- Hartbearbeitung bis 60 HRC möglich
- Zum HSC-Schlichten geeignet

Applications – material (see page 6)

- Especially suitable for high-strength materials
- For almost all materials
- Hard machining of up to 60 HRC
- Suitable for HSC finishing

ALCR

P	1.1-5.1
M	1.1-2.1 3.1-4.1
K	1.1-2.1 2.2
K	3.1-4.1 4.2
N	1.1-1.4
N	2.1-3.2 4.1-4.2, 5.2
S	1.1-2.2 2.3
S	2.4 2.5-2.6
H	1.1-1.3

Bestell-Code · Order code

$\alpha/2$	$\varnothing d_1$	r_1	r_2	r_3	l_2	l_1	$\varnothing d_2$ h6	Z (Flutes)	Dimens.- Code	3541L		
12,5°	16	2	1000	5	31	108	16	6	.1610AA	●		
	16	4	1000	5	24	108	16	6	.1610AB	●		
20°	10	2	250	5	12,5	80	10	6	.10250A	●		
	12	3	250	6	13,5	93	12	6	.12250A	●		
	16	4	500	8	18,5	108	16	6	.16500A	●		
	16	4	1500	8	18,5	108	16	6	.1615AA	●		
42,5°	12	1	200	1	8	93	12	6	.12200A	●		
60°	10	1	200	1,5	6	80	10	4	.10200A		●	
70°	10	1	200	2	6	80	10	4	.10200B		●	

Nur mit Anstellwinkel $\alpha/2$ einsetzen!
Only use with tilt angle $\alpha/2$!

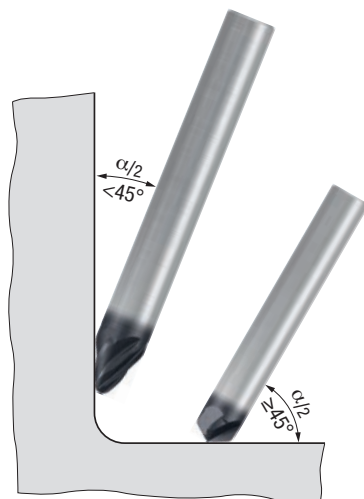

Hartmetall-Kreissegment-Fräser mit Kegelform – VR
Solid carbide circle segment end mills with taper form – VR

N

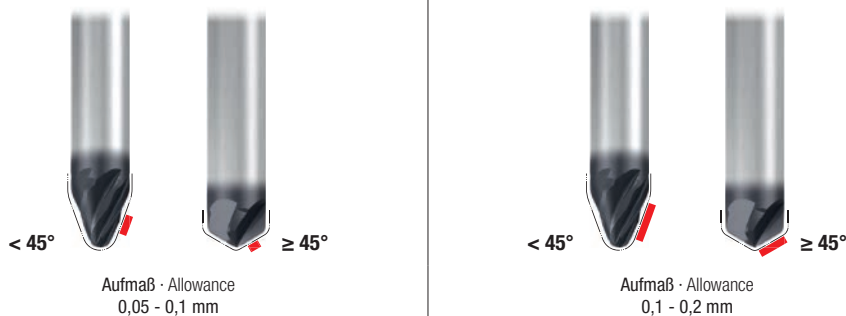

Gültig für · Valid for
3541L

Für die Berechnung der Drehzahl n muss mit dem Durchmesser d_1 gerechnet werden.

In order to calculate the rotational speed n, the diameter d_1 has to be used.



		Aufmaß - Allowance 0,05 - 0,1 mm		Aufmaß - Allowance 0,1 - 0,2 mm					
		V_c [m/min]	f_z [mm]	V_c [m/min]	f_z [mm]				
P	1.1	420	$0,003 \times d_1$	420	$0,002 \times d_1$	<input type="checkbox"/>	<input checked="" type="checkbox"/>	<input type="checkbox"/>	<input checked="" type="checkbox"/>
	2.1	375	$0,003 \times d_1$	375	$0,002 \times d_1$	<input type="checkbox"/>	<input checked="" type="checkbox"/>	<input type="checkbox"/>	<input checked="" type="checkbox"/>
	3.1	315	$0,002 \times d_1$	315	$0,002 \times d_1$	<input type="checkbox"/>	<input checked="" type="checkbox"/>	<input type="checkbox"/>	<input checked="" type="checkbox"/>
	4.1	300	$0,002 \times d_1$	300	$0,001 \times d_1$	<input type="checkbox"/>	<input checked="" type="checkbox"/>		
	5.1	270	$0,002 \times d_1$	270	$0,001 \times d_1$	<input type="checkbox"/>	<input checked="" type="checkbox"/>		
M	1.1	150	$0,003 \times d_1$	150	$0,002 \times d_1$			<input type="checkbox"/>	<input checked="" type="checkbox"/>
	2.1	120	$0,003 \times d_1$	120	$0,002 \times d_1$			<input type="checkbox"/>	<input checked="" type="checkbox"/>
	3.1	90	$0,002 \times d_1$	90	$0,001 \times d_1$			<input type="checkbox"/>	<input checked="" type="checkbox"/>
	4.1	60	$0,002 \times d_1$	60	$0,001 \times d_1$			<input type="checkbox"/>	<input checked="" type="checkbox"/>
K	1.1	280	$0,004 \times d_1$	280	$0,003 \times d_1$	<input type="checkbox"/>	<input checked="" type="checkbox"/>		
	1.2	280	$0,004 \times d_1$	280	$0,003 \times d_1$	<input type="checkbox"/>	<input checked="" type="checkbox"/>		
	2.1	250	$0,003 \times d_1$	250	$0,002 \times d_1$	<input type="checkbox"/>	<input checked="" type="checkbox"/>		
	2.2	250	$0,003 \times d_1$	250	$0,002 \times d_1$	<input type="checkbox"/>	<input checked="" type="checkbox"/>		
	3.1	210	$0,003 \times d_1$	210	$0,002 \times d_1$	<input type="checkbox"/>	<input checked="" type="checkbox"/>		
	3.2	210	$0,003 \times d_1$	210	$0,002 \times d_1$	<input type="checkbox"/>	<input checked="" type="checkbox"/>		
	4.1	180	$0,002 \times d_1$	180	$0,001 \times d_1$	<input type="checkbox"/>	<input checked="" type="checkbox"/>		
	4.2	140	$0,002 \times d_1$	140	$0,001 \times d_1$	<input type="checkbox"/>	<input checked="" type="checkbox"/>		
N	1.1	600	$0,003 \times d_1$	600	$0,002 \times d_1$			<input type="checkbox"/>	<input checked="" type="checkbox"/>
	1.2	600	$0,003 \times d_1$	600	$0,002 \times d_1$			<input type="checkbox"/>	<input checked="" type="checkbox"/>
	1.3	600	$0,002 \times d_1$	600	$0,001 \times d_1$			<input type="checkbox"/>	<input checked="" type="checkbox"/>
	1.4	410	$0,003 \times d_1$	410	$0,002 \times d_1$			<input type="checkbox"/>	<input checked="" type="checkbox"/>
	1.5								
	1.6								
	2.1	270	$0,004 \times d_1$	270	$0,003 \times d_1$			<input type="checkbox"/>	<input checked="" type="checkbox"/>
	2.2	270	$0,004 \times d_1$	270	$0,003 \times d_1$			<input type="checkbox"/>	<input checked="" type="checkbox"/>
	2.3	270	$0,004 \times d_1$	270	$0,003 \times d_1$		<input type="checkbox"/>	<input type="checkbox"/>	<input checked="" type="checkbox"/>
	2.4	255	$0,003 \times d_1$	255	$0,002 \times d_1$		<input type="checkbox"/>	<input type="checkbox"/>	<input checked="" type="checkbox"/>
	2.5	255	$0,003 \times d_1$	255	$0,002 \times d_1$		<input type="checkbox"/>	<input type="checkbox"/>	<input checked="" type="checkbox"/>
	2.6	255	$0,003 \times d_1$	255	$0,002 \times d_1$		<input type="checkbox"/>	<input type="checkbox"/>	<input checked="" type="checkbox"/>
	2.7	150	$0,002 \times d_1$	150	$0,001 \times d_1$		<input type="checkbox"/>	<input type="checkbox"/>	<input checked="" type="checkbox"/>
	2.8	150	$0,002 \times d_1$	150	$0,001 \times d_1$		<input type="checkbox"/>	<input type="checkbox"/>	<input checked="" type="checkbox"/>
	3.1	410	$0,004 \times d_1$	410	$0,003 \times d_1$			<input type="checkbox"/>	<input checked="" type="checkbox"/>
	3.2	410	$0,004 \times d_1$	410	$0,003 \times d_1$			<input type="checkbox"/>	<input checked="" type="checkbox"/>
4.1	410	$0,004 \times d_1$	410	$0,003 \times d_1$		<input type="checkbox"/>	<input type="checkbox"/>	<input checked="" type="checkbox"/>	
4.2	600	$0,004 \times d_1$	600	$0,003 \times d_1$		<input type="checkbox"/>	<input type="checkbox"/>	<input checked="" type="checkbox"/>	
4.3									
4.4									
5.1									
5.2	150	$0,003 \times d_1$	150	$0,002 \times d_1$				<input checked="" type="checkbox"/>	
5.3									
S	1.1	100	$0,005 \times d_1$	100	$0,004 \times d_1$				<input checked="" type="checkbox"/>
	1.2	80	$0,004 \times d_1$	80	$0,003 \times d_1$				<input checked="" type="checkbox"/>
	1.3	60	$0,004 \times d_1$	60	$0,003 \times d_1$				<input checked="" type="checkbox"/>
	2.1	80	$0,003 \times d_1$	80	$0,002 \times d_1$				<input checked="" type="checkbox"/>
	2.2	30	$0,003 \times d_1$	30	$0,002 \times d_1$				<input checked="" type="checkbox"/>
	2.3	30	$0,003 \times d_1$	30	$0,002 \times d_1$				<input checked="" type="checkbox"/>
	2.4	30	$0,003 \times d_1$	30	$0,002 \times d_1$				<input checked="" type="checkbox"/>
	2.5	30	$0,003 \times d_1$	30	$0,002 \times d_1$				<input checked="" type="checkbox"/>
2.6	30	$0,003 \times d_1$	30	$0,002 \times d_1$				<input checked="" type="checkbox"/>	
H	1.1	130	$0,004 \times d_1$	130	$0,003 \times d_1$	<input type="checkbox"/>	<input checked="" type="checkbox"/>		
	1.2	100	$0,004 \times d_1$	100	$0,003 \times d_1$	<input type="checkbox"/>	<input checked="" type="checkbox"/>		
	1.3	80	$0,003 \times d_1$	80	$0,002 \times d_1$	<input type="checkbox"/>	<input checked="" type="checkbox"/>		
	1.4								
	1.5								

v_c = Schnittgeschwindigkeit · Cutting speed
 f_z = Vorschub pro Zahn · Feed per tooth

= sehr gut geeignet · very suitable
 = gut geeignet · suitable

- Hochleistungswerkzeug
- Mit 3 Schneiden
- Vibrationsarme Bearbeitung
- Hocheffiziente Schlichtbearbeitung
- Formtoleranz $\pm 0,01$ mm

- High performance tool
- With 3 flutes
- Low-vibration machining
- Highly efficient finishing
- Form tolerance ± 0.01 mm

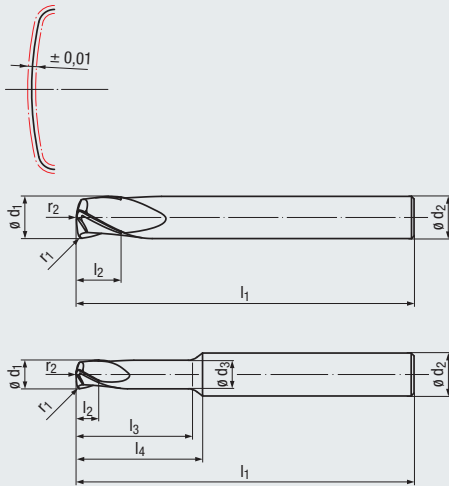

N

HM

DIN 6535
HA
HB

Form
 $\pm 0,01$

30°

V_c / f_z
19

Optional

Linsenform – ER
Lens Form – ER



Allround

Beschichtung · Coating

Einsatzgebiete – Material (siehe Seite 6)

- Speziell für hochfeste Werkstoffe geeignet
- In fast allen Werkstoffen einsetzbar
- Zum HSC-Schlichten geeignet

Applications – material (see page 6)

- Especially suitable for high-strength materials
- For almost all materials
- Suitable for HSC finishing

ALCR

P	1.1-5.1	
M	1.1-2.1	3.1-4.1
K	1.1-2.1	2.2
K	3.1-4.1	4.2
N	1.1-1.4	
N	2.1-3.2	5.2
S	1.1-2.1	

Bestell-Code · Order code

ϕd_1	r_1	r_2	l_2	l_3	l_1	ϕd_3	l_4	ϕd_2 h6	Z (Flutes)	Dimens.- Code
4	0,25	6	4	18	62	4	20	6	3	.04006A
6	0,5	10	6	–	62	–	–	6	3	.06010A
8	0,75	15	8	–	68	–	–	8	3	.08015A
10	1	20	10	–	80	–	–	10	3	.10020A
12	1,25	25	12	–	93	–	–	12	3	.12025A

3544L

Bearbeitungsbeispiel

Bauteil: Integralbauteil aus der Luftfahrtindustrie

Anwendung: Schlichtbearbeitung der tiefen Taschen und der Bodenflächen

Machining example

Component: Integral component from the aviation industry

Application: Finishing of the deep pockets and the bottom surfaces



Hartmetall-Kreissegment-Fräser mit Linsenform – ER
Solid carbide circle segment end mill with lens form – ER

N



Aufmaß · Allowance
0,05 - 0,1 mm



Aufmaß · Allowance
0,1 - 0,2 mm

Gültig für · Valid for
3544L

Für die Berechnung der Drehzahl n muss mit dem Durchmesser d_1 gerechnet werden.

In order to calculate the rotational speed n, the diameter d_1 has to be used.



	V_c [m/min]	f_z [mm]	V_c [m/min]	f_z [mm]			MMS MQL		
P	1.1	420	$0,004 \times d_1$	420	$0,003 \times d_1$	<input type="checkbox"/>	<input checked="" type="checkbox"/>	<input type="checkbox"/>	<input checked="" type="checkbox"/>
	2.1	375	$0,004 \times d_1$	375	$0,003 \times d_1$	<input type="checkbox"/>	<input checked="" type="checkbox"/>	<input type="checkbox"/>	<input checked="" type="checkbox"/>
	3.1	315	$0,003 \times d_1$	315	$0,003 \times d_1$	<input type="checkbox"/>	<input checked="" type="checkbox"/>	<input type="checkbox"/>	<input checked="" type="checkbox"/>
	4.1	300	$0,003 \times d_1$	300	$0,002 \times d_1$	<input type="checkbox"/>	<input checked="" type="checkbox"/>		
	5.1	270	$0,003 \times d_1$	270	$0,002 \times d_1$	<input type="checkbox"/>	<input checked="" type="checkbox"/>		
M	1.1	150	$0,005 \times d_1$	150	$0,003 \times d_1$			<input type="checkbox"/>	<input checked="" type="checkbox"/>
	2.1	120	$0,005 \times d_1$	120	$0,003 \times d_1$			<input type="checkbox"/>	<input checked="" type="checkbox"/>
	3.1	90	$0,004 \times d_1$	90	$0,002 \times d_1$			<input type="checkbox"/>	<input checked="" type="checkbox"/>
	4.1	60	$0,004 \times d_1$	60	$0,002 \times d_1$			<input type="checkbox"/>	<input checked="" type="checkbox"/>
K	1.1	300	$0,005 \times d_1$	300	$0,004 \times d_1$	<input type="checkbox"/>	<input checked="" type="checkbox"/>		
	1.2	300	$0,005 \times d_1$	300	$0,004 \times d_1$	<input type="checkbox"/>	<input checked="" type="checkbox"/>		
	2.1	270	$0,004 \times d_1$	270	$0,003 \times d_1$	<input type="checkbox"/>	<input checked="" type="checkbox"/>		
	2.2	270	$0,004 \times d_1$	270	$0,003 \times d_1$	<input type="checkbox"/>	<input checked="" type="checkbox"/>		
	3.1	220	$0,004 \times d_1$	220	$0,003 \times d_1$	<input type="checkbox"/>	<input checked="" type="checkbox"/>		
	3.2	220	$0,004 \times d_1$	220	$0,003 \times d_1$	<input type="checkbox"/>	<input checked="" type="checkbox"/>		
	4.1	200	$0,003 \times d_1$	200	$0,002 \times d_1$	<input type="checkbox"/>	<input checked="" type="checkbox"/>		
	4.2	150	$0,003 \times d_1$	150	$0,002 \times d_1$	<input type="checkbox"/>	<input checked="" type="checkbox"/>		
N	1.1	900	$0,004 \times d_1$	900	$0,003 \times d_1$			<input type="checkbox"/>	<input checked="" type="checkbox"/>
	1.2	900	$0,004 \times d_1$	900	$0,003 \times d_1$			<input type="checkbox"/>	<input checked="" type="checkbox"/>
	1.3	900	$0,003 \times d_1$	900	$0,002 \times d_1$			<input type="checkbox"/>	<input checked="" type="checkbox"/>
	1.4	600	$0,004 \times d_1$	600	$0,003 \times d_1$			<input type="checkbox"/>	<input checked="" type="checkbox"/>
	1.5								
	1.6								
	2.1	270	$0,004 \times d_1$	270	$0,003 \times d_1$			<input type="checkbox"/>	<input checked="" type="checkbox"/>
	2.2	270	$0,004 \times d_1$	270	$0,003 \times d_1$			<input type="checkbox"/>	<input checked="" type="checkbox"/>
	2.3	270	$0,004 \times d_1$	270	$0,003 \times d_1$		<input type="checkbox"/>	<input type="checkbox"/>	<input checked="" type="checkbox"/>
	2.4	255	$0,003 \times d_1$	255	$0,002 \times d_1$		<input type="checkbox"/>	<input type="checkbox"/>	<input checked="" type="checkbox"/>
	2.5	255	$0,003 \times d_1$	255	$0,002 \times d_1$		<input type="checkbox"/>	<input type="checkbox"/>	<input checked="" type="checkbox"/>
	2.6	255	$0,003 \times d_1$	255	$0,002 \times d_1$		<input type="checkbox"/>	<input type="checkbox"/>	<input checked="" type="checkbox"/>
	2.7	150	$0,003 \times d_1$	150	$0,002 \times d_1$		<input type="checkbox"/>	<input type="checkbox"/>	<input checked="" type="checkbox"/>
	2.8	150	$0,003 \times d_1$	150	$0,002 \times d_1$		<input type="checkbox"/>	<input type="checkbox"/>	<input checked="" type="checkbox"/>
	3.1	600	$0,004 \times d_1$	600	$0,003 \times d_1$			<input type="checkbox"/>	<input checked="" type="checkbox"/>
	3.2	600	$0,004 \times d_1$	600	$0,003 \times d_1$			<input type="checkbox"/>	<input checked="" type="checkbox"/>
4.1									
4.2									
4.3									
4.4									
5.1									
5.2	150	$0,005 \times d_1$	150	$0,003 \times d_1$				<input checked="" type="checkbox"/>	
5.3									
S	1.1	150	$0,006 \times d_1$	150	$0,004 \times d_1$				<input checked="" type="checkbox"/>
	1.2	120	$0,005 \times d_1$	120	$0,003 \times d_1$				<input checked="" type="checkbox"/>
	1.3	90	$0,005 \times d_1$	90	$0,003 \times d_1$				<input checked="" type="checkbox"/>
	2.1	120	$0,004 \times d_1$	120	$0,002 \times d_1$				<input checked="" type="checkbox"/>
	2.2								
	2.3								
2.4									
2.5									
2.6									
H	1.1								
	1.2								
	1.3								
	1.4								
	1.5								

v_c = Schnittgeschwindigkeit · Cutting speed
 f_z = Vorschub pro Zahn · Feed per tooth

= sehr gut geeignet · very suitable
 = gut geeignet · suitable

- Hochleistungswerkzeug
- Mit 4 Schneiden
- Ungleiche Teilung
- Vibrationsarme Bearbeitung
- Hocheffiziente Schruppbearbeitung
- High performance tool
- With 4 flutes
- Variable spacing
- Low-vibration machining
- Highly efficient roughing

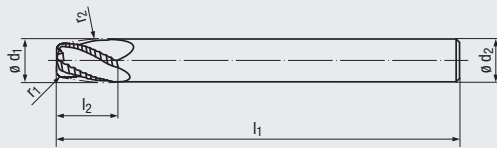
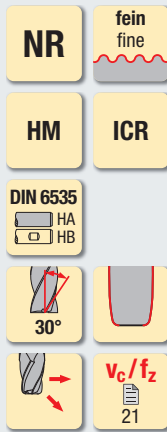

Tropfenform – ER
Oval Form – ER



Allround

Beschichtung · Coating

Einsatzgebiete – Material (siehe Seite 6)

- Speziell für hochfeste Werkstoffe geeignet
- Auch für Nickel-Basis-Legierungen einsetzbar
- Für die Zerspaltung von Titan-Legierungen geeignet
- Einsatz in allen Turbinenwerkstoffen möglich
- Optimierte zur Vorbearbeitung von Impellern und Integrated Bladed Rotors (IBR) aus Aluminium, Titan und Inconel

Applications – material (see page 6)

- Especially suitable for high-strength materials
- Also suitable in nickel-base alloys
- For the machining of titanium alloys
- Suitable in all turbine materials
- Optimised for pre-finishing Impellers and Integrated Bladed Rotors (IBR) made from aluminium, titanium and Inconel

ALCR

- P 1.1-5.1
- M 1.1-4.1
- N 1.1-1.3
- S 1.1-1.3
- S 2.2-2.6

Bestell-Code · Order code

d ₁	r ₁	r ₂	l ₂	l ₁	∅ d ₂ h6	Z (Flutes)	Dimens.- Code	3552LZ			
8	1	40	12	80	8	4	.08040A	●			
10	1,5	45	12	95	10	4	.10045A	●			
12	2	50	14	100	12	4	.12050A	●			
16	2	60	18	128	16	4	.16060A	●			

Baumaße für Werkzeugdatenbank

Dimensions for tool database

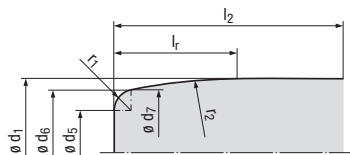

d ₁	r ₁	r ₂	l ₂	l _r	∅ d ₅	∅ d ₆	∅ d ₇
8	1	40	12	10	3,895	5,841	5,895
10	1,5	45	12	10	5,323	8,265	8,323
12	2	50	14	12	5,894	9,806	9,894
16	2	60	18	16	8,570	12,452	12,570

l_r = r₂ trifft tangential auf d₁
r₂ is tangential to d₁

d₆ = Tangentialpunkt von r₁ und r₂
Tangent point of r₁ and r₂

d₇ = d₅ + 2 x r₁

EMUGE-FRANKEN-Werkzeuge sind bereit für Industrie 4.0.

Ab sofort steht der digitale Zwilling zu vielen unserer Katalogwerkzeuge für Sie zum Download auf unserer Homepage bereit.

EMUGE-FRANKEN tools are ready for Industry 4.0.

From now on the digital twin created for a wide variety of our catalogue tools can be downloaded directly from our homepage.

tooldata.ef-apps.de

Kreissegment-Fräser mit Tropfenform – ER
 Circle segment end mills with oval form – ER

NR

Gültig für · Valid for
 3552LZ

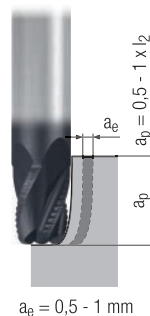
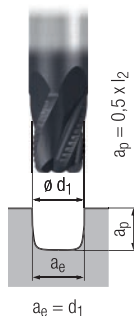

	V_c [m/min]	f_z [mm]	V_c [m/min]	f_z [mm]			MMS MQL		
P	1.1	100	$0,004 \times d_1$	140	$0,005 \times d_1$		■	□	■
	2.1	90	$0,004 \times d_1$	130	$0,004 \times d_1$		■	□	■
	3.1	90	$0,003 \times d_1$	120	$0,004 \times d_1$		■	□	■
	4.1	80	$0,002 \times d_1$	110	$0,003 \times d_1$		■	□	■
	5.1	70	$0,002 \times d_1$	100	$0,003 \times d_1$		■	□	■
M	1.1	80	$0,004 \times d_1$	100	$0,005 \times d_1$				■
	2.1	70	$0,003 \times d_1$	80	$0,004 \times d_1$				■
	3.1	60	$0,002 \times d_1$	70	$0,003 \times d_1$				■
	4.1	60	$0,002 \times d_1$	70	$0,003 \times d_1$				■
K	1.1								
	1.2								
	2.1								
	2.2								
	3.1								
	3.2								
	4.1								
N	1.1	280	$0,006 \times d_1$	400	$0,006 \times d_1$				■
	1.2	200	$0,005 \times d_1$	280	$0,005 \times d_1$				■
	1.3	140	$0,004 \times d_1$	200	$0,004 \times d_1$				■
	1.4								
	1.5								
	1.6								
	2.1								
	2.2								
	2.3								
	2.4								
	2.5								
	2.6								
	2.7								
	2.8								
	3.1								
3.2									
4.1									
4.2									
4.3									
4.4									
5.1									
5.2									
5.3									
S	1.1	90	$0,002 \times d_1$	120	$0,004 \times d_1$				■
	1.2	75	$0,002 \times d_1$	100	$0,003 \times d_1$				■
	1.3	45	$0,002 \times d_1$	60	$0,002 \times d_1$				■
	2.1								
	2.2	25	$0,002 \times d_1$	30	$0,002 \times d_1$				■
	2.3	25	$0,002 \times d_1$	30	$0,002 \times d_1$				■
2.4	25	$0,002 \times d_1$	30	$0,002 \times d_1$				■	
2.5	15	$0,002 \times d_1$	20	$0,002 \times d_1$				■	
2.6	25	$0,002 \times d_1$	30	$0,002 \times d_1$				■	
H	1.1								
	1.2								
	1.3								
	1.4								
	1.5								

v_c = Schnittgeschwindigkeit · Cutting speed
 f_z = Vorschub pro Zahn · Feed per tooth

■ = sehr gut geeignet · very suitable
 □ = gut geeignet · suitable

- Hochleistungswerkzeug
- Mit 4 Schneiden
- Ungleiche Teilung
- Vibrationsarme Bearbeitung
- Hocheffiziente Schlichtbearbeitung
- Formtoleranz $\pm 0,01$ mm

- High performance tool
- With 4 flutes
- Variable spacing
- Low-vibration machining
- Highly efficient finishing
- Form tolerance ± 0.01 mm

N

HM **ICR**

DIN 6535
 HA HB

Form
 $\pm 0,01$

30°

V_c/f_z
23

Tropfenform – ER
Oval Form – ER



Allround

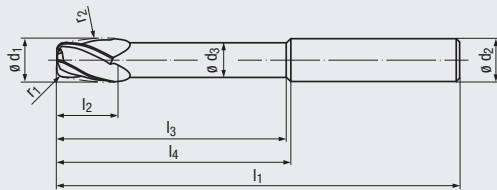
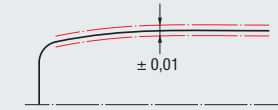

Beschichtung · Coating

Einsatzgebiete – Material (siehe Seite 6)

- Speziell für hochfeste Werkstoffe geeignet
- Auch für Nickel-Basis-Legierungen einsetzbar
- Für die Zerspaltung von Titan-Legierungen geeignet
- Einsatz in allen Turbinenwerkstoffen möglich
- Optimiert zur Fertigbearbeitung von Impellern und Integrated Bladed Rotors (IBR) aus Aluminium, Titan und Inconel

Applications – material (see page 6)

- Especially suitable for high-strength materials
- Also suitable in nickel-base alloys
- For the machining of titanium alloys
- Suitable in all turbine materials
- Optimised for finishing Impellers and Integrated Bladed Rotors (IBR) made from aluminium, titanium and Inconel

ALCR

- P** 1.1-5.1
- M** 1.1-4.1
- N** 1.1-1.3
- S** 1.1-1.3
- S** 2.2-2.6

Bestell-Code · Order code

d ₁	r ₁	r ₂	l ₂	l ₁	l ₃	l ₄	∅ d ₃	∅ d ₂ h ₆	Z (Flutes)	Dimens.- Code	3554LZ
8	1	40	12	80	42	44	7	8	4	.08040A	●
10	1,5	45	12	95	52	55	8,5	10	4	.10045A	●
12	2	50	14	100	61	65	10	12	4	.12050A	●
16	2	60	18	128	76	80	14	16	4	.16060A	●

Baumaße für Werkzeugdatenbank

Dimensions for tool database

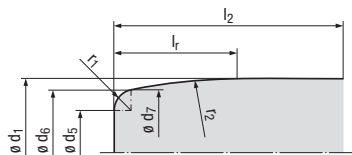

d ₁	r ₁	r ₂	l ₂	l _r	∅ d ₅	∅ d ₆	∅ d ₇
8	1	40	12	10	3,895	5,841	5,895
10	1,5	45	12	10	5,323	8,265	8,323
12	2	50	14	12	5,894	9,806	9,894
16	2	60	18	16	8,570	12,452	12,570

$l_r = r_2$ trifft tangential auf d_1
 r_2 is tangential to d_1

$d_6 =$ Tangentialpunkt von r_1 und r_2
Tangent point of r_1 and r_2

$d_7 = d_5 + 2 \times r_1$

EMUGE-FRANKEN-Werkzeuge sind bereit für Industrie 4.0.

Ab sofort steht der digitale Zwilling zu vielen unserer Katalogwerkzeuge für Sie zum Download auf unserer Homepage bereit.

EMUGE-FRANKEN tools are ready for Industry 4.0.

From now on the digital twin created for a wide variety of our catalogue tools can be downloaded directly from our homepage.

tooldata.ef-apps.de

Kreissegment-Fräser mit Tropfenform – ER
Circle segment end mills with oval form – ER

N

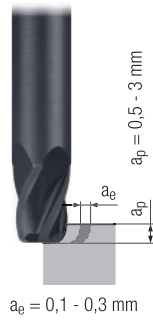

Gültig für · Valid for
3554LZ

		v_c [m/min]	f_z [mm]			MMS MQL	
P	1.1	200	$0,005 \times d_1$		■	□	■
	2.1	180	$0,004 \times d_1$		■	□	■
	3.1	160	$0,004 \times d_1$		■	□	■
	4.1	140	$0,003 \times d_1$		■	□	■
	5.1	120	$0,003 \times d_1$		■	□	■
M	1.1	120	$0,005 \times d_1$				■
	2.1	100	$0,004 \times d_1$				■
	3.1	80	$0,003 \times d_1$				■
	4.1	80	$0,003 \times d_1$				■
K	1.1						
	1.2						
	2.1						
	2.2						
	3.1						
	3.2						
	4.1						
N	1.1	400	$0,006 \times d_1$				■
	1.2	280	$0,005 \times d_1$				■
	1.3	200	$0,004 \times d_1$				■
	1.4						
	1.5						
	1.6						
	2.1						
	2.2						
	2.3						
	2.4						
	2.5						
	2.6						
	2.7						
	2.8						
	3.1						
	3.2						
4.1							
4.2							
4.3							
4.4							
5.1							
5.2							
5.3							
S	1.1	120	$0,005 \times d_1$				■
	1.2	100	$0,004 \times d_1$				■
	1.3	60	$0,003 \times d_1$				■
	2.1						
	2.2	30	$0,003 \times d_1$				■
	2.3	30	$0,002 \times d_1$				■
	2.4	30	$0,003 \times d_1$				■
2.5	20	$0,002 \times d_1$				■	
2.6	30	$0,002 \times d_1$				■	
H	1.1						
	1.2						
	1.3						
	1.4						
	1.5						

v_c = Schnittgeschwindigkeit · Cutting speed
 f_z = Vorschub pro Zahn · Feed per tooth

■ = sehr gut geeignet · very suitable
□ = gut geeignet · suitable

- Hocheffiziente Schlichtbearbeitung
- Formtoleranz ±0,01 mm

- High efficient finishing
- Form tolerance ±0.01 mm

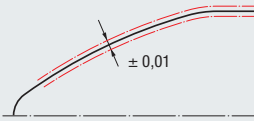
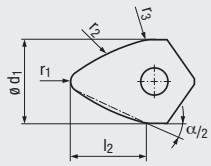

HM

Form
± 0,01



V_c/f_z
26



Allround

Schneidstoff · Cutting material

KP1

Beschichtung · Coating

TIALN

Einsatzgebiete – Material (siehe Seite 6)

Applications – material (see page 6)

- Speziell für hochfeste Werkstoffe geeignet
- In fast allen Werkstoffen einsetzbar

- Especially suitable for high-strength materials
- For almost all materials

P	1.1-5.1	
M	1.1-2.1	3.1-4.1
K	1.1-2.1	2.2
K	3.1-4.1	4.2
N	1.1-1.4	
N	2.1-3.2	4.1-4.2, 5.2
S	1.1-2.2	2.3
S	2.4	2.5-2.6
H		1.1-1.2

Bestell-Code · Order code

9563A

$\alpha/2$	$\varnothing d_1$	r ₁	r ₂	r ₃	l ₂	Z (Flutes)	Dimens.- Code		
20°	16	2	40	8	17,8	2	.16040A	●	
	16	2	100	8	17,1	2	.16100A	●	
	20	3	40	8	21,7	2	.20040A	●	
	20	3	100	8	20,8	2	.20100A	●	
25°	16	2	40	8	13,4	2	.16040B	●	
	16	2	100	8	13	2	.16100B	●	
	20	3	40	8	16,6	2	.20040B	●	
	20	3	100	8	16	2	.20100B	●	
35°	16	2	40	5	8,8	2	.16040C	●	
	16	2	100	5	8,7	2	.16100C	●	
	20	3	40	5	11	2	.20040C	●	
	20	3	100	5	10,8	2	.20100C	●	

- Schafffräskörper mit Hartmetall-Schaft
- Für die HSC-Bearbeitung
- Innere Kühlschmierstoff-Zufuhr, Austritt radial (ICR)
- Hohe Wechselgenauigkeit durch V-Klemmung ($\pm 0,01$)

- Indexable end mill with carbide shank
- For HSC machining
- Internal coolant supply, radial exit (ICR)
- High exchange precision due to V-clamping (± 0.01)

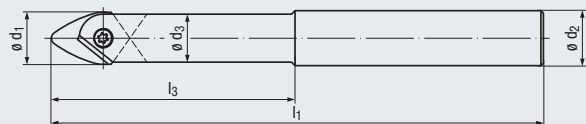

Bestell-Code · Order code							9003	
$\varnothing d_1$	l_3	l_1	$\varnothing d_3$	$\varnothing d_2$ h6	$n_{max.}$ min ⁻¹	Dimens.- Code		
16	55	110	15,5	16	32 000	.160552	●	
16	85	150	15,5	16	32 000	.160852	●	
16	120	200	15,5	16	32 000	.161202	●	
20	65	110	19,5	20	28 000	.200652	●	
20	85	150	19,5	20	28 000	.200852	●	
20	120	200	19,5	20	28 000	.201202	●	

Lieferumfang: ohne Wechselschneidplatten, mit Torx-Schrauben
Delivery: without inserts, with Torx screws

Kreissegment-Wechselschneidplatten siehe Seite 24
Circle segment inserts, see page 24

Zubehör · Accessories

Schraubendreher · Screwdriver



Bestell-Code · Order code			9855
$\varnothing d_1$	Größe Size	Dimens.- Code	
16-20	Torx T20	.20	●

Spannschraube · Clamping Screw



Bestell-Code · Order code				9817
$\varnothing d_1$	Größe Size	M_d max.	Dimens.- Code	
16	M5 x 12,5 x Torx T20	1 Nm	.1620	●
20	M5 x 15 x Torx T20	2,25 Nm	.2020	●

Hochtemperatur-Schraubenpaste · High-Temperature Screw Paste



Bestell-Code · Order code		9000
Menge Quantity	Dimens.- Code	
100 g	.000	●

Sicherstellung der Lösbarkeit von Torx-Schrauben für Wendeschneidplatten durch leichtes Einfetten von Gewinde und Senkkopf!

Applying a light coating of grease on thread and countersunk head ensures that the Torx screws for the inserts can be loosened again.

Kreissegment-Wechselschneidplatten
Circle segment inserts

Gültig für · Valid for
9563A



Aufmaß · Allowance
0,05 - 0,1 mm



Aufmaß · Allowance
0,1 - 0,2 mm

Für die Berechnung der Drehzahl n muss mit dem Durchmesser d₁ gerechnet werden.

In order to calculate the rotational speed n, the diameter d₁ has to be used.



	V _C [m/min]	f _Z [mm]	V _C [m/min]	f _Z [mm]			MMS MQL		
P	1.1	340	0,004 x d ₁	340	0,003 x d ₁	<input type="checkbox"/>	<input checked="" type="checkbox"/>	<input type="checkbox"/>	<input checked="" type="checkbox"/>
	2.1	300	0,004 x d ₁	300	0,003 x d ₁	<input type="checkbox"/>	<input checked="" type="checkbox"/>	<input type="checkbox"/>	<input checked="" type="checkbox"/>
	3.1	250	0,003 x d ₁	250	0,003 x d ₁	<input type="checkbox"/>	<input checked="" type="checkbox"/>	<input type="checkbox"/>	<input checked="" type="checkbox"/>
	4.1	240	0,003 x d ₁	240	0,002 x d ₁	<input type="checkbox"/>	<input checked="" type="checkbox"/>		
	5.1	215	0,003 x d ₁	215	0,002 x d ₁	<input type="checkbox"/>	<input checked="" type="checkbox"/>		
M	1.1	120	0,004 x d ₁	120	0,003 x d ₁			<input type="checkbox"/>	<input checked="" type="checkbox"/>
	2.1	95	0,004 x d ₁	95	0,003 x d ₁			<input type="checkbox"/>	<input checked="" type="checkbox"/>
	3.1	70	0,003 x d ₁	70	0,002 x d ₁			<input type="checkbox"/>	<input checked="" type="checkbox"/>
	4.1	50	0,003 x d ₁	50	0,002 x d ₁			<input type="checkbox"/>	<input checked="" type="checkbox"/>
K	1.1	225	0,007 x d ₁	225	0,004 x d ₁	<input type="checkbox"/>	<input checked="" type="checkbox"/>		
	1.2	225	0,007 x d ₁	225	0,004 x d ₁	<input type="checkbox"/>	<input checked="" type="checkbox"/>		
	2.1	200	0,006 x d ₁	200	0,003 x d ₁	<input type="checkbox"/>	<input checked="" type="checkbox"/>		
	2.2	200	0,006 x d ₁	200	0,003 x d ₁	<input type="checkbox"/>	<input checked="" type="checkbox"/>		
	3.1	170	0,006 x d ₁	170	0,003 x d ₁	<input type="checkbox"/>	<input checked="" type="checkbox"/>		
	3.2	170	0,006 x d ₁	170	0,003 x d ₁	<input type="checkbox"/>	<input checked="" type="checkbox"/>		
	4.1	145	0,004 x d ₁	145	0,002 x d ₁	<input type="checkbox"/>	<input checked="" type="checkbox"/>		
	4.2	110	0,003 x d ₁	110	0,002 x d ₁	<input type="checkbox"/>	<input checked="" type="checkbox"/>		
N	1.1	480	0,004 x d ₁	480	0,003 x d ₁			<input type="checkbox"/>	<input checked="" type="checkbox"/>
	1.2	480	0,004 x d ₁	480	0,003 x d ₁			<input type="checkbox"/>	<input checked="" type="checkbox"/>
	1.3	480	0,003 x d ₁	480	0,002 x d ₁			<input type="checkbox"/>	<input checked="" type="checkbox"/>
	1.4	330	0,004 x d ₁	330	0,003 x d ₁			<input type="checkbox"/>	<input checked="" type="checkbox"/>
	1.5								
	1.6								
	2.1	215	0,005 x d ₁	215	0,004 x d ₁			<input type="checkbox"/>	<input checked="" type="checkbox"/>
	2.2	215	0,005 x d ₁	215	0,004 x d ₁			<input type="checkbox"/>	<input checked="" type="checkbox"/>
	2.3	215	0,005 x d ₁	215	0,004 x d ₁	<input type="checkbox"/>		<input type="checkbox"/>	<input checked="" type="checkbox"/>
	2.4	200	0,004 x d ₁	200	0,003 x d ₁			<input type="checkbox"/>	<input checked="" type="checkbox"/>
	2.5	200	0,004 x d ₁	200	0,003 x d ₁			<input type="checkbox"/>	<input checked="" type="checkbox"/>
	2.6	200	0,004 x d ₁	200	0,003 x d ₁			<input type="checkbox"/>	<input checked="" type="checkbox"/>
	2.7	120	0,003 x d ₁	120	0,002 x d ₁		<input type="checkbox"/>	<input type="checkbox"/>	<input checked="" type="checkbox"/>
	2.8	120	0,003 x d ₁	120	0,002 x d ₁			<input type="checkbox"/>	<input checked="" type="checkbox"/>
	3.1	330	0,005 x d ₁	330	0,004 x d ₁			<input type="checkbox"/>	<input checked="" type="checkbox"/>
	3.2	330	0,005 x d ₁	330	0,004 x d ₁			<input type="checkbox"/>	<input checked="" type="checkbox"/>
4.1	330	0,005 x d ₁	330	0,004 x d ₁		<input type="checkbox"/>	<input type="checkbox"/>	<input checked="" type="checkbox"/>	
4.2	480	0,005 x d ₁	480	0,004 x d ₁			<input type="checkbox"/>	<input checked="" type="checkbox"/>	
4.3									
4.4									
5.1									
5.2	120	0,004 x d ₁	120	0,003 x d ₁				<input checked="" type="checkbox"/>	
5.3									
S	1.1	80	0,005 x d ₁	80	0,004 x d ₁				<input checked="" type="checkbox"/>
	1.2	65	0,004 x d ₁	65	0,003 x d ₁				<input checked="" type="checkbox"/>
	1.3	50	0,004 x d ₁	50	0,003 x d ₁				<input checked="" type="checkbox"/>
	2.1	65	0,003 x d ₁	65	0,002 x d ₁				<input checked="" type="checkbox"/>
	2.2	25	0,003 x d ₁	25	0,002 x d ₁				<input checked="" type="checkbox"/>
	2.3	25	0,003 x d ₁	25	0,002 x d ₁				<input checked="" type="checkbox"/>
2.4	25	0,003 x d ₁	25	0,002 x d ₁				<input checked="" type="checkbox"/>	
2.5	25	0,003 x d ₁	25	0,002 x d ₁				<input checked="" type="checkbox"/>	
2.6	25	0,003 x d ₁	25	0,002 x d ₁				<input checked="" type="checkbox"/>	
H	1.1	100	0,005 x d ₁	100	0,003 x d ₁	<input type="checkbox"/>	<input checked="" type="checkbox"/>		
	1.2	80	0,005 x d ₁	80	0,003 x d ₁	<input type="checkbox"/>	<input checked="" type="checkbox"/>		
	1.3								
	1.4								
	1.5								

Durch die Verwendung von gekühlter Luft wird die Temperatur im Schneidenbereich herabgesetzt, wodurch höhere Schnittgeschwindigkeiten und Standzeiten erreicht werden können. Moderne Beschichtungen können durch diese Art der Kühlung erst alle Vorteile ausspielen, da eine Schädigung der Schneide durch Thermoschock vermieden wird.

Darüber hinaus werden die beim Kopierfräsen anfallenden sehr leichten Späne auch aus tiefen Aussparungen oder Kavitäten mit Hilfe der Kaltluftdüse entfernt.

Die Wirkungsweise der Kaltluftdüse basiert auf dem Prinzip des Wirbelrohrs, in dem zwei gegenläufige, rotierende Luftströme (ohne bewegte Teile) erzeugt werden. An einem Ende tritt die innere Strömung als nutzbare Kaltluft mit bis zu -40 °C aus. Der Anschluss erfolgt über einen Druckluftanschluss.

Cooled air reduces temperatures in the cutting area, which in turn permits higher cutting speeds and longer tool life. This type of cooling enables modern coatings to achieve their full potential, as damage to the cutting edge resulting from thermal shock is avoided.

Moreover, the cold-air nozzle helps to remove the tiny chips produced in copy milling even from deep recesses or cavities.

The function of the cold-air nozzle is based on the principle of the vortex tube, in which two opposed, rotating air streams are generated (without any moving parts). The internal air stream exits from one end, in the form of useable cold air with a temperature as low as -40 °C. All that is required is a normal pressurised air connection.

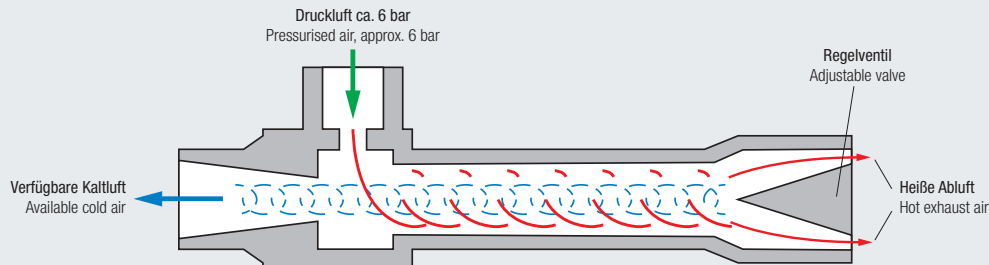

Temperatur gemessen am effektiven Austritt des Wirbelrohrs (nicht Düsenende)

Temperature, measured at the effective exit of the vortex tube (not the end of the nozzle)

Zuluft-Druck Supply air pressure [bar]	Temperatur der Nutzluft in °C bei einem Kaltluftanteil von Temperature of usable air in °C, with a cold air percentage of		
	25%	50%	75%
3	-31	-22	- 6
4	-35	-35	- 8
5	-39	-28	-10
6	-42	-31	-11
7	-46	-34	-13

Luftverbrauch bei Eingangstemperatur von 21 °C

Air consumption, with supply air temperature of 21 °C

Eingangsdruck Input pressure [bar]	Luftverbrauch Air consumption	Kapazität Capacity
6,9	7,08 l/s \cong 25,5 m ³ /h	226 kcal/h \cong 263 W

Anwendungsbeispiel:

Standzeiterhöhung durch den Einsatz der Kaltluftdüse

Werkstück: Formeinsatz gehärtet, Material 1.2343 (X38CrMoV5-1) mit 46-48 HRC

Bearbeitung: Schruppen des Formeinsatzes
Werkzeug: Time-S-Cut Einschraub-Fräskörper 9130.350524 (FRANKEN Katalog 250, Seite 218) mit Wendeschneidplatten 9585A.08015 (FRANKEN Katalog 250, Seite 216)

Schnittwerte: $v_c = 150 \text{ m/min} \cdot n = 1364 \text{ min}^{-1}$
 $f_z = 1,11 \text{ mm} \cdot v_f = 6057 \text{ mm/min}$
 $a_p = 0,4 \text{ mm} \cdot a_e = 20 \text{ mm}$

Standzeit ohne Kühlung	Standzeit mit Kaltluftdüse
50 Minuten	68 Minuten

Durch den Einsatz der Kaltluftdüse konnte die Standzeit um 36% erhöht werden.

Application example:

Increased tool life using the cold-air nozzle

Workpiece: Hardened mould, material hot work tool steel 1.2343 (X38CrMoV5-1) with 46-48 HRC

Operation: Roughing the mould
Tool: Time-S-Cut screw-in end mill 9130.350524 (FRANKEN Catalogue 250, page 218) with inserts 9585A.08015 (FRANKEN Catalogue 250, page 216)

Cutting conditions: $v_c = 150 \text{ m/min} \cdot n = 1364 \text{ rpm}$
 $f_z = 1.11 \text{ mm} \cdot v_f = 6057 \text{ mm/min}$
 $a_p = 0.4 \text{ mm} \cdot a_e = 20 \text{ mm}$

Tool life without coolant	Tool life with cold-air nozzle
50 minutes	68 minutes

By using the cold-air nozzle, it was possible to increase the tool life by 36%.

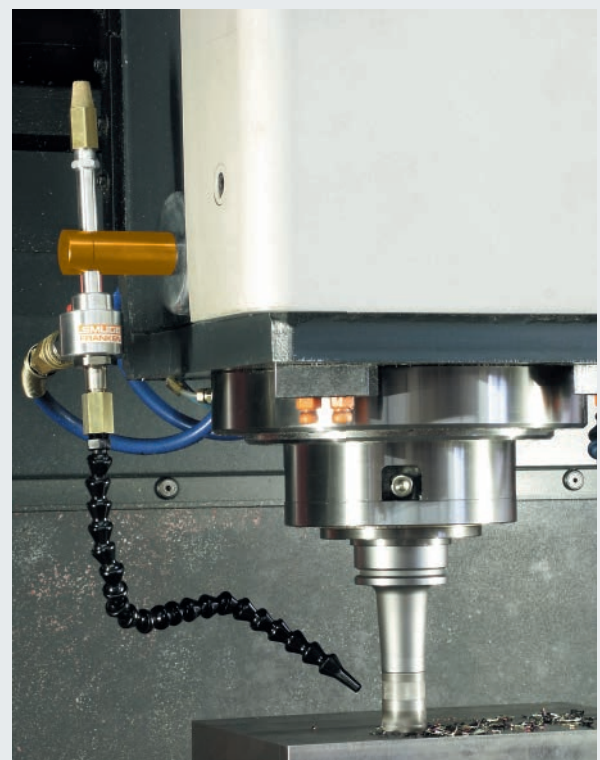

Kaltluftdüse
Cold-Air Nozzle

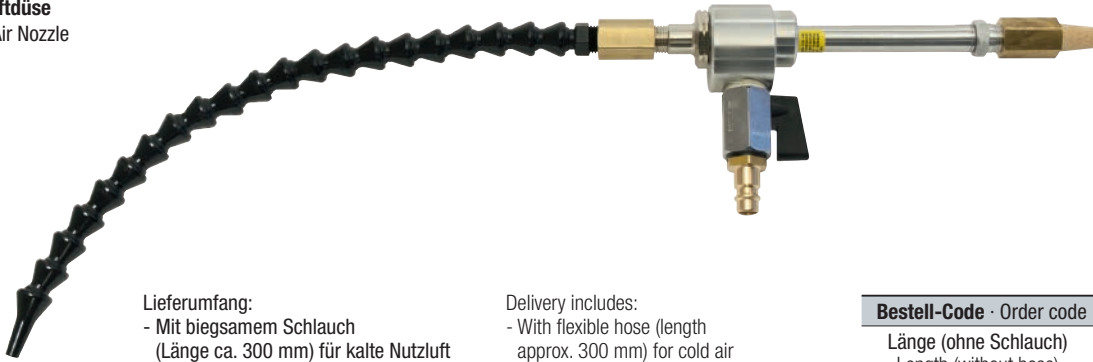

Lieferumfang:
- Mit biegsamem Schlauch
(Länge ca. 300 mm) für kalte Nutzluft
- Schalldämpfer (SN14) für heiße Abluft
- Kugelhahn mit Anschlussstück (ST 1/4)
für Zuluftschlauch (NW6)
mit Schnellwechselkupplung (NW7.2)

Delivery includes:
- With flexible hose (length
approx. 300 mm) for cold air
- Silencer (SN14) for hot exhaust air
- Ball-valve with fitting (1/4") for inlet
hose (6 mm) with quick-change
attachment (7.2 mm)

Bestell-Code · Order code		6910
Länge (ohne Schlauch) Length (without hose)	Dimens.- Code	
225 mm	.15	●

Ersatzschlauch
Spare Hose



Bestell-Code · Order code		6910
Länge Length	Dimens.- Code	
≈ 300 mm	.20	●
≈ 400 mm	.22	●
≈ 500 mm	.21	●

Halterungen für die Kaltluftdüse
Holders for the Cold-Air Nozzle



Klemmarm mit Grundhalter
Socket with basic holder



Klemmarm mit Magnethalter
Socket with magnetic shoe



Klemmarm
Socket



Grundhalter für Klemmarm
Basic holder for socket



Magnethalter für Klemmarm
Magnetic shoe for socket

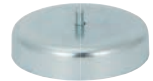

Bestell-Code · Order code		6910				
Abmaße Dimensions	Dimens.- Code					
ø 45 x 68 mm	.24	●				
ø 80 x 80 mm	.25		●			
ø 80 x 17 mm	.26					●
ø 32 x 63 mm	.27			●		
ø 45 x 20 mm	.32				●	

Kaltluftdüsen-Anbausset
Cold-Air Nozzle Attachment Set



Bestell-Code · Order code		6910
	Dimens.-Code	
	.12	●

- Lieferumfang:
- 1 x Klemmarm mit Grundhalter (Art.-Nr.: 6910.24)
 - 1 x Anschluss Schlauch 300 mm
 - 1 x Winkel-Verschraubung G 1/4
 - 1 x Verschraubung G 1/4
 - 2 x Blindstopfen G 1/4

- Delivery includes:
- 1 x Socket with basic holder (art. No. 6910.24)
 - 1 x Connecting hose 300 mm
 - 1 x Elbow coupling G 1/4
 - 1 x Screw G 1/4
 - 2 x Sealing plugs G 1/4

Kaltluftdüsen-Montageset 1
Cold-Air Nozzle Assembly Set 1



Bestehend aus 1 Kaltluftdüse (Art.-Nr. 6910.15) und 1 Kaltluftdüsen-Anbausset (Art.-Nr. 6910.12)
Consists of 1 cold-air nozzle (art. no. 6910.15) and 1 cold-air nozzle attachment set (art. no. 6910.12)



Bestell-Code · Order code		6910
	Dimens.-Code	
	.11	●

Kaltluftdüsen-Montageset 2
Cold-Air Nozzle Assembly Set 2



Bestehend aus 2 Kaltluftdüsen (Art.-Nr. 6910.15) und 2 Kaltluftdüsen-Anbausets (Art.-Nr. 6910.12)
Consists of 2 cold-air nozzles (art. no. 6910.15) and 2 cold-air nozzle attachment sets (art. no. 6910.12)

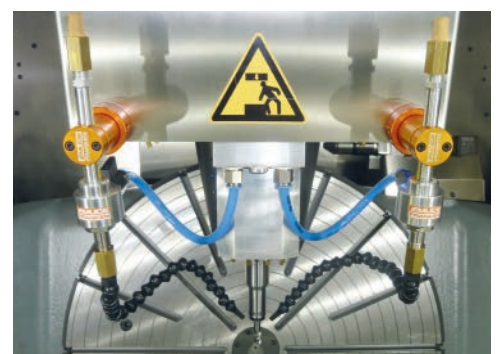

Bestell-Code · Order code		6910
	Dimens.-Code	
	.10	●



Mehr als 100 Jahre Präzision und Innovation. More than 100 years of precision and innovation.

FRANKEN als Teil der EMUGE-FRANKEN Unternehmensgruppe beschäftigt sich seit seiner Gründung mit der Entwicklung und Produktion von Fräswerkzeugen. Präzision und Innovation prägen das breite Angebot von Fräsern aus Hartmetall und HSS sowie PKD-, CBN- oder wendeplattenbestückten Fräskörpern.

Die Fertigung am deutschen Produktionsstandort in Rückersdorf reicht von Standard-Schaft- und Bohrungsfräsern bis hin zu hochgenauen Form- und Profil-Sonderfräsern. Mit seiner Typen- und Schneidstoffvielfalt, dem hohen Standard und der kompromisslosen Präzision entspricht das Fräserprogramm den höchsten Qualitätsanforderungen.

Als Ergänzung zu den Fräswerkzeugen führen wir ein durchgängiges Programm an Fräsespannmitteln und Zubehör für die verschiedensten Adaptierungsmöglichkeiten.

Ever since its foundation FRANKEN as part of the EMUGE-FRANKEN company association has been developing and manufacturing milling tools. The wide range of end mills of solid carbide and HSS as well as PCD and CBN inserts or milling cutters with indexable inserts is characterised by precision and innovation.

The production in our German manufacturing plant in Rückersdorf includes standard end mills and bore cutters as well as highly precise special form and profile milling tools. With its large variety of tool types and cutting materials, the consistently high standards and uncompromising precision, our product range of milling cutters meets even the highest quality requirements.

In addition to our selection of milling tools, we also offer a comprehensive range of clamping systems, tool holders and accessories.

**EMUGE-FRANKEN ist nach
ISO 9001:2015 zertifiziert**
EMUGE-FRANKEN is certified
according ISO 9001:2015



www.sgs-tuev-saar.com
Certification ID
DE/819944190



In unseren Unternehmen ist die Abteilung „Anwendungstechnik“ die Service- und Dienstleistungsabteilung für den weltweit bestehenden Kundenkreis. Für die von EMUGE-FRANKEN angebotenen Produkte stellt dieses Expertenteam folgende Leistungen zur Verfügung:

- Weltweite telefonische Beratung und Unterstützung bei der Lösung technischer Probleme
- Mitarbeit bei der Erarbeitung von Konzepten und Vorschlägen zur Optimierung des Fertigungsablaufes beim Kunden
- Durchführung von Versuchen mit spezifischen Kundenmaterialien in einer eigens dafür eingerichteten Versuchsabteilung zur optimalen Werkzeugauswahl und -empfehlung
- Entwicklung und Konstruktion kundenspezifischer Sonderwerkzeuge
- Einsatz von Servicetechnikern
- Durchführung von produktbezogenen Schulungen und Seminaren weltweit

At EMUGE-FRANKEN, the Technical Service Department is the service and consulting partner for our customers worldwide. Our team of service technicians will be happy to help you in any of the following ways:

- Worldwide telephone consulting and support in the solution of technical problems
- Active support in the development of work strategies and in the optimisation of production processes
- Cutting trials with specific customer materials in a special workshop fitted exclusively for that purpose, for the perfect tool selection
- Development and construction of special tools made to customer's specifications
- Visits to customers' workshops and active support on location
- Product-related training courses and seminars arranged at any place worldwide

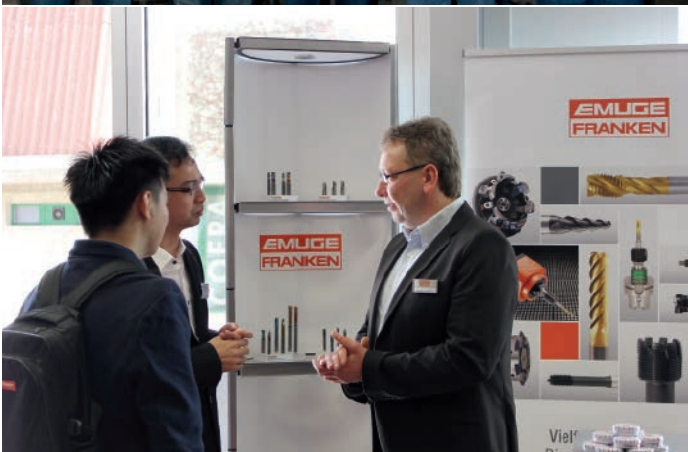
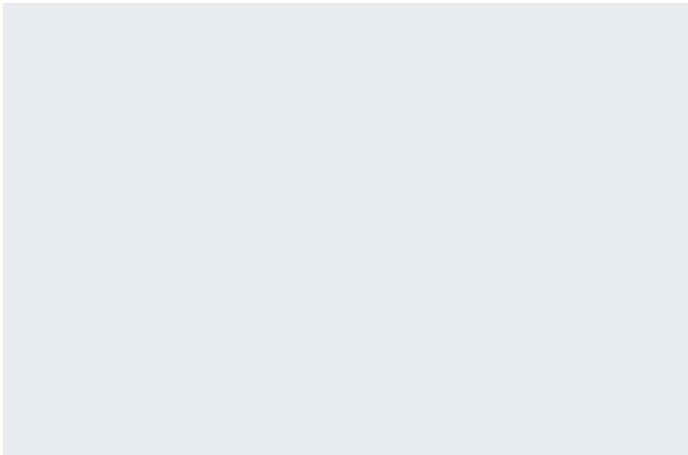

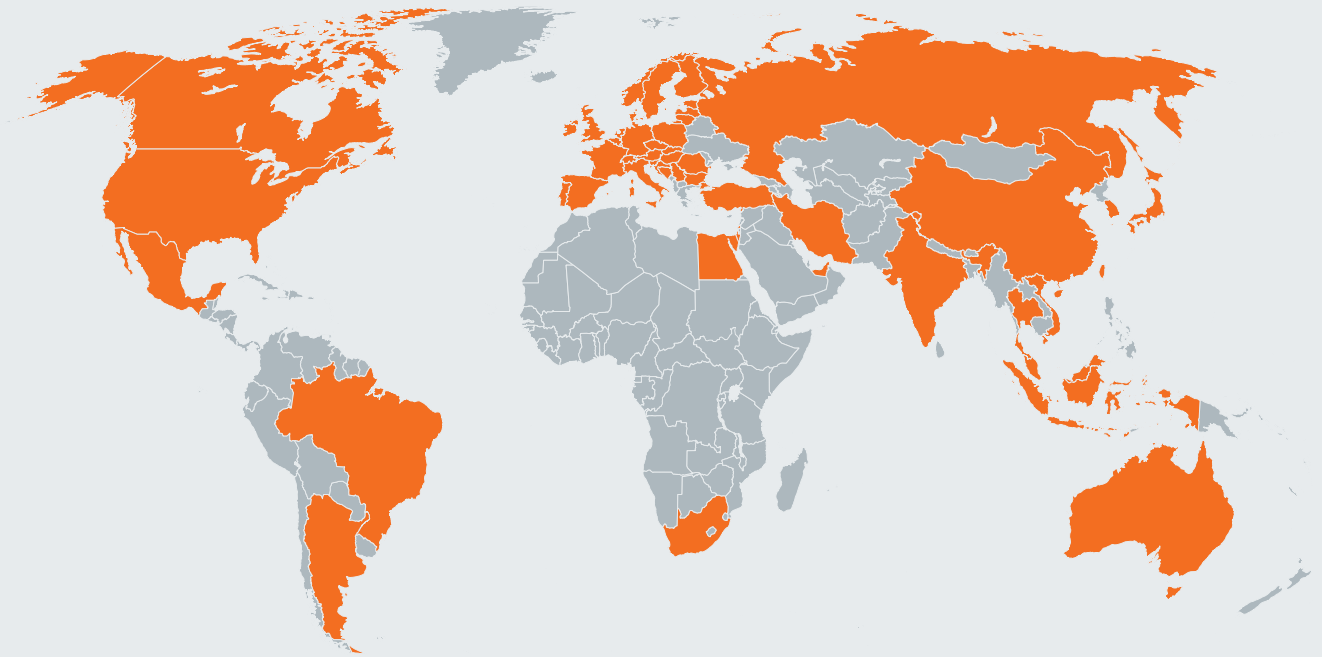

EMUGE-FRANKEN Vertriebspartner finden Sie auf www.emuge-franken.com/vertrieb
EMUGE-FRANKEN sales partners, please see www.emuge-franken.com/sales

EMUGE-Werk Richard Glimpel GmbH & Co. KG
Fabrik für Präzisionswerkzeuge

🏠 Nürnberger Straße 96-100
91207 Lauf
GERMANY

☎ +49 9123 186-0
📠 +49 9123 14313

FRANKEN GmbH & Co. KG
Fabrik für Präzisionswerkzeuge

🏠 Frankenstraße 7/9a
90607 Rückersdorf
GERMANY

☎ +49 911 9575-5
📠 +49 911 9575-327

✉ info@emuge-franken.com 🌐 www.emuge-franken.com